



HAROLD HABEGGER SA
FABRIQUE DE MACHINES
OUTILLAGE
ROUTE DE CHALUET 5/9
CH-2738 COURT (SUISSE)

TÉL. ++41 32 497 97 55
FAX ++41 32 497 93 08

INTERNET: www.habegger-sa.com
E-MAIL: contact@habegger-sa.com

SERVICE INSTRUCTIONS :

THREAD ROLLING DIES HABEGGER

Table of contents

1	GENERAL REMARKS.....	2
1.1	Main advantages of thread rolling :	2
1.2	Materials	2
2	DESCRIPTION	2
2.1	Adjustable thread rolling dies.....	2
2.2	Die holders for adjustable thread rolling dies.....	3
2.2.1	Habegger die holders type R	3
2.2.2	Habegger die holders type R with compensating system	3
2.2.3	Habegger die holders for ESCO D2GR43 and D6R	4
2.3	Non-adjustable thread rolling dies	4
2.4	Die holders for non adjustable thread rolling dies.....	5
2.4.1	Habegger die holders type N.....	5
2.4.2	Habegger die holders type F.....	5
2.4.3	Habegger die holders type V.....	5
3	SPECIAL THREADS.....	5
3.1	Multiple threads.....	5
3.2	Thread rolling on tubes	6
3.3	L.H. threads.....	6
3.4	Special profiles.....	6
4	CLEARED-OFF STUDS	6
4.1	Description	6
4.2	Table of standard pitches	6
5	THREAD ROLLING CONDITIONS	7
5.1	General remarks.....	7
5.2	Engagement of the rolling die	7
5.3	Turning the blank part.....	7
5.3.1	Indicative tables	7
5.3.2	Calculation for other thread dimensions.....	8
5.3.3	Example of calculation.....	8
5.3.4	Practical information	9
5.4	Stuffing	9
5.5	Breakage of the rollers.....	9
5.6	Reversing of rollers.....	9
5.6.1	R.h. threads and double pitch l.h.	10
5.6.2	L.h. threads and double pitch r.h.	10
6	SPARE PARTS	10
6.1	Thread rolling die.....	10
6.2	Die holder	10
7	STARTING CAM (for cam controlled machines)	11
7.1	Working angle of the engaging cam.....	11
7.2	Practical example:	11
7.3	Machining of the cam.....	11
8	DIFFICULT ENGAGING START.....	12

1 GENERAL REMARKS

1.1 Main advantages of thread rolling:

- Better thread quality
- High machining regularity
- Increased thread resistance
- Reduced breaking points
- Better surface values on the thread flanks and on the thread root

There are two types of Habegger thread rolling dies, i.e.:

- 1) **Adjustable** thread rolling dies
- 2) **Non-adjustable** thread rolling die

Habegger thread rolling dies are used with success for watch and instruments screws, spectacle screws etc. They are highly recommended for stainless steel and Titan screws. Assemble the die into the correct Habegger die holder as described below.

1.2 Materials

Materials for which the use of Habegger thread rolling dies are considered as economical production means, are the following: smooth steel, brass, nickel silver, aluminium, 20 AP steel (basic material to check the non-adjustable thread rolling dies), stainless steel, Titan.

Thread rolling will not be possible with materials like lead or synthetics, with cast iron or other easily breaking materials.

2 DESCRIPTION

2.1 Adjustable thread rolling dies

Part designations:

- 1 body (1)
- 3 rollers (2)
- 3 studs (3)

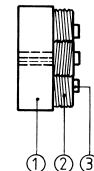
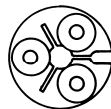

The diameter on the thread flank can be adjusted by means of the nut of type R die holders. The outside diameter is adjusted by modifying the turning diameter before thread rolling. Take care that the thread is not full **and that a slight flat remains on top of the profile.**



Returned diameter too small



Returned diameter ok



Returned diameter too large

These dies permit to compensate the wear on rollers and studs, but they need more attention from the operator. We supply spare parts (rollers) for this kind of dies, as the final adjustment is done by the operator.



All threading effected as second operations must be done with adjustable thread rolling dies.

2.2 Die holders for adjustable thread rolling dies

Adjustable Habegger thread rolling dies are mounted in a Habegger die holder type R. Such die holders are available with or without compensating device. When the dies must be used on ESCO machines of the type D2GR43 and D6R, we supply the die holders corresponding to each of the said machines.

2.2.1 Habegger die holders type R

Part designations:

- 1 body (1)
- 1 counter-nut (2)
- 1 nut (3)

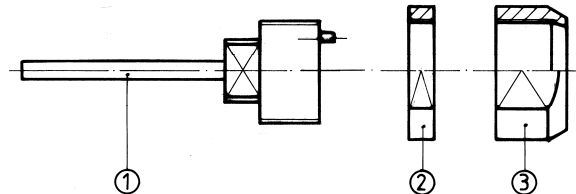

Instructions for the adjustment of die holder R:

- a) After the assembly of the adjustable thread rolling die on its holder, tighten the nut (3) by hand, until it leans against the die, **without closing** it. Lock the nut with the counter-nut (2).
- b) Prepare the part of the workpiece which will be rolled. The turning diameter must correspond to the dimensions given in the table of point 5.3. In any case this diameter must be a little smaller than the theoretical flank diameter of the screw (for profiles ISO/DIN 60° without flat bottom only: outside diameter of the screw – (0.649 x screw pitch)). This proceeding prevents the die from stuffing at the first attempt to roll the thread.
- c) The first rolling done will show great flats on the summit of the profiles. Now, proceed to adjust the die, acting on the nut (3). Thus the die is slightly closed. Continue this way until the control gauges of the thread engage correctly. **The flats must always be seen on the summit of the profiles whilst you adjust the die.**
- d) When the flank diameter corresponds to the control gauges, the setting will be secured by locking the nut (3) with the counter-nut (2).
- e) Then you will increase slightly and progressively the turning diameter, until you obtain the correct profile.
- f) **Care! A small flat must be seen on the top of the profiles. This is a testimony of not filling up.** It is a sign that the die moves the material but doesn't compress it! That flat is essential for the life of your die.
- g) **During the production check carefully that flat at the summit of the profile. If necessary, compensate the wear of the tool which turns the front diameter.** Whilst wearing, this tool produces a turning diameter that gets always greater.

2.2.2 Habegger die holders type R with compensating system

When the thread rolling dies are used on fixed headstock turning machines or on CNC machines, a die holder with compensating system must be chosen. This Habegger system permits to compensate the feed differences between the die (according to the pitch) and the machine.

At the engagement and during the whole threading operation, the machines 'feed will be slightly lower than the pitch/rotation ratio. **The pitch is only given by the thread rolling die, without external stress.** The return spring permits this compensation.

The working feed is calculated as follows: **pitch x 0.98.**

At the return motion, the feed is of 1.10 x the value of the pitch.

Parts designations:

- 1 screw (7)
- 1 sleeve washer (6)
- 1 compensating spring (5)
- 1 sleeve (4)
- 1 shaft-body (1)
- 1 counter-nut (2)
- 1 nut (3)

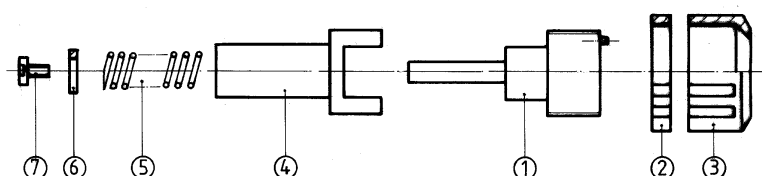

2.2.3 Habegger die holders for ESCO D2GR43 and D6R

When the dies must be used on ESCO machines of the type D2GR43 and D6R, we supply the die holders corresponding to each of the said machines.

a) ESCO type D2GR43:

- 1 sleeve (1)
- 1 plate (2)
- 1 nut (3)

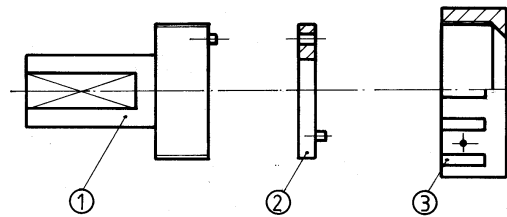

b) ESCO type D6R:

- 1 plate (2)
- 1 nut (3)

Adjustment is effected in the same way as for *Habegger* die holders type R, but the locking of the nut is obtained by means of two radial screws instead of a counter-nut.

2.3 Non-adjustable thread rolling dies

Part designations:

- 1 body (1)
- 3 rollers (2)
- 3 studs (3)

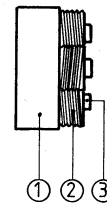
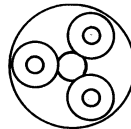

They are available in hundredths of millimetres (0.01 mm) in the usual threading tolerances.

These non-adjustable thread rolling dies are supplied for a diameter determined by the tolerances of the workpiece thread. **The tolerances and the material must be indicated at order.** When working, the diameter of the dies will slightly increase. It is therefore advised to choose dies to the minimum of the tolerances.

Example: workpiece : 0.90+0/-0.02
die : 0.885

When the customer uses the non-adjustable Habegger thread rolling dies for the first time, we supply dies that are slightly over the minimum tolerance, in order to avoid breakage of the rollers due to filling up the teeth to their maximum.

These dies have the advantage to be independent from a false adjustment by the inattention of the operator. However, contrarily to adjustable dies, their life time is directly bound to the wear of the rollers and studs.

All non-adjustable dies are tested in 20 AP steel. We could establish an equality rule. For example, if the equality is 0.59 for 20 AP steel, we will supply an equality of 0.58 for stainless steel and of 0.60 for smooth turning steel. If the material is tougher than the test material, the rollers will have a tendency to spread out a little more. Inversely, if the material is smoother.

We don't supply spare parts for non-adjustable thread rolling dies.

2.4 Die holders for non-adjustable thread rolling dies

Non-adjustable thread rolling dies are assembled on the machines with the help of 3 types of die holders: the types N, F and V (see general catalogue).

2.4.1 Habegger die holders type N

Part designations:

- 1 shaft (1)
- 1 nut (2)
- 1 head (3)

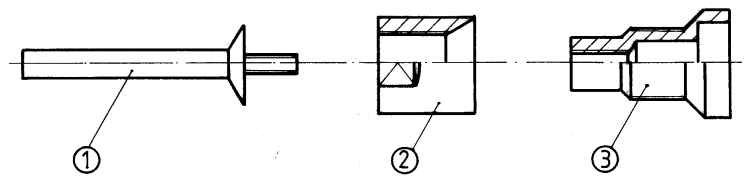

This construction permits to dismantle the head (3) with its nut (2) and the die, without loosening the shaft (1). Thus, errors due to an eventual inattention after an exchange of dies will be avoided. It makes cleaning outside of the machine easier. These thread rolling die holders are mainly used on cam-controlled machines.

2.4.2 Habegger die holders type F

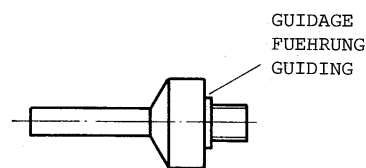

These die holders are made of a single piece. They take up dies that are hold by means of a thread. A guiding diameter gives the correct position. There are special die holders for left hand dies (L dies).

2.4.3 Habegger die holders type V

Part designations:

- 1 die holder (1)
- 3 fixations screws (2)

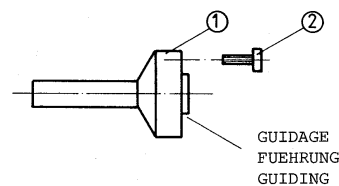

These die holders are in single piece. They take dies maintained by 3 front screws. A guiding diameter gives the correct position. These die holder are mainly used on multi-spindle machines.

3 SPECIAL THREADS

3.1 Multiple threads

- Double thread

Dies for double threads are available. At the order, we imperatively need to know if the indicated pitch is real or apparent:

Example: MDP 6.00 x 1.00

Real pitch : 1 pitch = 1 mm
 Apparent pitch : ½ pitch = 0.5 mm

- Triple thread

Also dies for triple threads are available.

3.2 Thread rolling on tubes

It is possible to roll threads on tubes with the Habegger thread rolling dies, in so far as the tube walls are solid enough. The tube will have a tendency to close. The material will yield toward the centre.

3.3 L.H. threads

All the dies are available for L. H. threading (type "L").

3.4 Special profiles

On demand, all kinds of dimensions and profiles can be studied, according to the customer's needs.

4 CLEARED-OFF STUDS

4.1 Description

On demand, we supply thread rolling dies with cleared-off studs to let pass the screw head, as sketched below:

$\varnothing A$ = Bar passage diameter between studs, without clearance.

$\varnothing B$ = Diameter of the recess

C = Unrolled shaft-length when the bar diameter exceeds the passing diameter between studs.

$\varnothing D$ = Outside diameter of the thread rolling die.

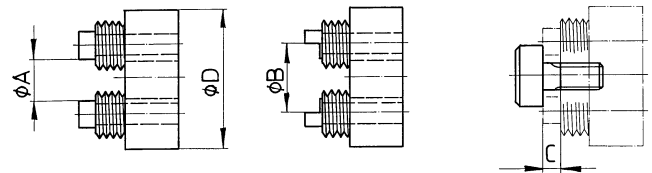

4.2 Table of standard pitches

\varnothing of thread x pitch	$\varnothing A$	$\varnothing B$	C	Adjustable $\varnothing D1$	Non-adjustable $\varnothing D2$
M 0.40 x 0.10	0.70	1.50	0.40	--	6
M 0.50 x 0.125	0.90	2.00	0.50	--	6
M 0.60 x 0.15	1.20	2.50	0.60	8	6
M 0.70 x 0.175	1.60	3.00	0.60	8	6
M 0.80 x 0.20	1.70	3.50	0.80	8	8
M 0.90 x 0.225	1.70	3.50	0.90	8	8
M 1.00 x 0.25	2.00	4.00	0.90	10	8
M 1.10 x 0.25	2.10	4.00	0.90	10	8
M 1.20 x 0.25	2.20	4.00	0.90	10	8
M 1.30 x 0.30	2.40	4.50	0.90	10	8/10
M 1.40 x 0.30	2.50	5.00	0.90	10	8/10
M 1.50 x 0.30	2.60	5.00	0.90	10	8/10
M 1.60 x 0.35	3.60	6.20	1.10	14	12
M 1.70 x 0.35	3.70	6.30	1.10	14	12
M 1.80 x 0.35	3.80	6.40	1.10	14	12
M 2.00 x 0.40	4.00	6.80	1.10	14	12
M 2.20 x 0.45	4.40	7.80	1.20	16	12/16
M 2.50 x 0.45	4.70	8.10	1.20	16	12/16
M 2.60 x 0.45	4.80	8.20	1.20	16	12/16
M 3.00 x 0.50 PM	5.10	8.50	1.30	16	12/16
M 3.00 x 0.50 GM	7.30	12.00	2.00	25	22
M 3.50 x 0.60	7.70	12.40	2.10	25	22
M 4.00 x 0.70	8.00	12.80	2.20	25	22
M 4.50 x 0.75	8.30	13.20	2.20	25	25
M 5.00 x 0.80	9.00	14.00	2.30	27	25
M 6.00 x 1.00	10.70	16.50	2.70	32	30
M 7.00 x 1.00	11.70	17.50	2.70	32	--
M 8.00 x 1.25	12.60	19.50	3.50	35	--

5 THREAD ROLLING CONDITIONS

5.1 General remarks

Thread rolling with *Habegger* rolling dies needs the same ratio as for cutting dies.



The peripheral speed of the workpiece will be between 5 - 50 m/min.

5.2 Engagement of the rolling die

To have an easier engagement of the rolling die on the workpiece, **it is necessary to foresee an angle of 15 to 20° at the axis**. The start effort is then reduced. The same angle must be foreseen at the end of the thread if the workpiece shows a groove. The more the angle is long, the more the conditions get better (see figure point 5.5).

5.3 Turning the blank part

The blank diameter "D" is defined by the nominal flank diameter less a value called safety value. That value takes in account the maximal tolerance zone of the standards (NIHS, 6h/6g or 2A/3A).



The tables and relations hereafter are only valid for standard threads with a profile angle of 60°.

These values do not match for other standards than those you find hereafter, neither for dies with flat bottom nor for other special profiles.

5.3.1 Indicative tables

- **Miniature threads (standards NIHS and ISO)**

Validity: Tolerances NIHS and ISO R1501

S and M	0.35	0.40	0.50	0.60	0.70	0.80	0.90	1.00	1.10	1.20
Pitch	0.090	0.100	0.125	0.150	0.175	0.200	0.225	0.250	0.250	0.250
Diameter "D"	0.27	0.31	0.39	0.48	0.55	0.63	0.71	0.79	0.90	1.00

- **Metric threads with normal pitch (DIN13 and ISO)**

Validity: Tolerances 6h/6g

M	1.30	1.40	1.50	1.60	1.70	1.80	2.00	2.20
Pitch	0.300	0.300	0.300	0.350	0.350	0.350	0.400	0.450
Diameter "D"	1.05	1.15	1.25	1.30	1.40	1.50	1.60	1.75

M	2.50	3.00	3.50	4.00	4.50	5.00	6.00	8.00
Pitch	0.450	0.500	0.600	0.700	0.750	0.800	1.000	1.250
Diameter "D"	2.05	2.50	2.90	3.35	3.80	4.25	5.10	6.95

5.3.2 Calculation for other thread dimensions

- **Metric fine pitch threads and not normalized (DIN13 and ISO)**

Validity: Tolerances 6h/6g

Nominal flank diameter = Nominal diameter - 0.64952 x pitch

D = Nominal flank diameter - z

z = factor for blank as per table below:

<i>Diameter smaller than 1.40 mm</i>			<i>Diameter greater than 1.40 mm</i>		
Pitch (mm)		Z (mm)	Pitch (mm)		Z (mm)
Smaller than: 0.06	up to: 0.15	0.04	Smaller than: 0.20	up to: 0.35	0.10
Smaller than: 0.15	up to: 0.20	0.05	Smaller than: 0.35	up to: 0.70	0.15
Smaller than: 0.20	up to: 0.30	0.06	Smaller than: 0.70	up to: 0.90	0.20

- **Unified Thread Standards (ASME/ANSI)**

Validity: Tolerances 2A/3A

Calculation of flank diameter: **Nominal flank diameter = Nominal diameter - 0.64952 x pitch**

Calculation of the blank diameter: **D = Nominal flank diameter - z**

Dimensions in mm

z = factor for blanks as per table below:

Pitch	Pitch (mm)	z (mm)
120 TPI	0.212	0.05
110 TPI	0.231	0.05
100 TPI	0.254	0.05
90 TPI	0.282	0.05
80 TPI	0.318	0.10
72 TPI	0.353	0.10
64 TPI	0.397	0.10
56 TPI	0.454	0.15
48 TPI	0.529	0.15
44 TPI	0.577	0.15
40 TPI	0.635	0.15
36 TPI	0.706	0.20
32 TPI	0.794	0.20
28 TPI	0.907	0.20
27 TPI	0.941	0.20
24 TPI	1.058	0.25
20 TPI	1.270	0.25

5.3.3 Example of calculation

Wanted thread: UNF 0-80 2A
 Nominal diameter: 0.0600 inches = 1.52mm
 Pitch: 80 TPI = 0.318 mm
 Flank diameter: 1.52 - 0.64952 x 0.318 = 1.31 mm
 Blank diameter: D = nominal flank diameter - z
D = 1.31 - 0.10 = 1.21mm

5.3.4 Practical information

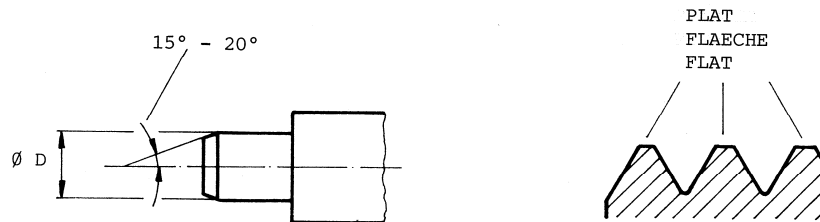

This blank diameter must be progressively increased, until a slight flat remains at the top of the thread. That flat must be kept to prevent stuffing or even wearing of the rolling die.

For a profile of 60°, an increase of 0.01 mm of the blank diameter will have, as a consequence, an increase of 0.03 mm of the outside diameter after rolling the thread. (Ratio 1:3).

5.4 Stuffing

If it should fill up in spite of this precaution, proceed as follows:

- 1) Chase the stud out with a stud-driver, pushing the die on a 3-jaw mandrel on a bench, but without clamping it.
- 2) Take away the material in the die.
- 3) Put back the roller in its place and chase the stud in. Take care that the roller revolves freely.

5.5 Breakage of the rollers

If the workpiece has a groove at the end of the thread, this groove must be correctly chamfered (A).

Otherwise, the first tooth of the roller n° 1, eventually that of the roller n° 2, will break off (B).

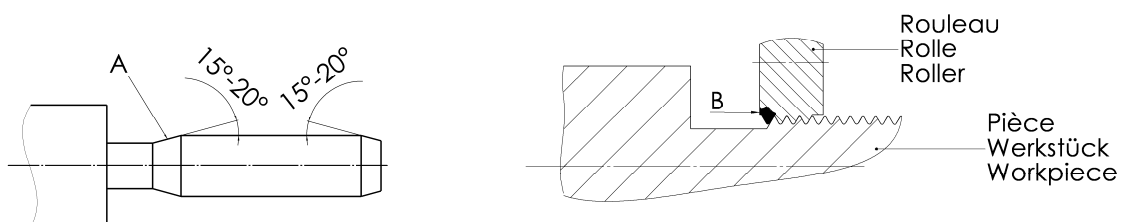

5.6 Reversing of rollers

When a roller got damaged, we may reverse it. In such a case, observe the following arrangement, as shown by the sketch below:

5.6.1 R.h. threads and double pitch l.h.

Taking off the pivots and reversing the rollers:

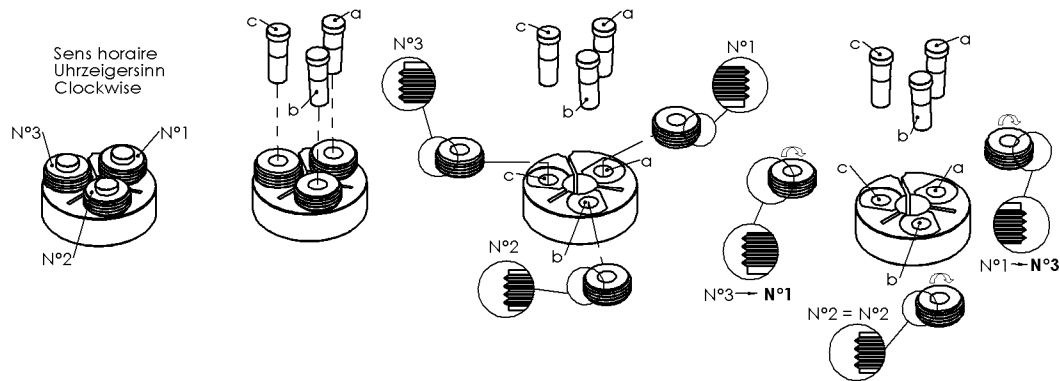

Assembly of the roll No 2, moving and assembling the rolls No 1 and No 3

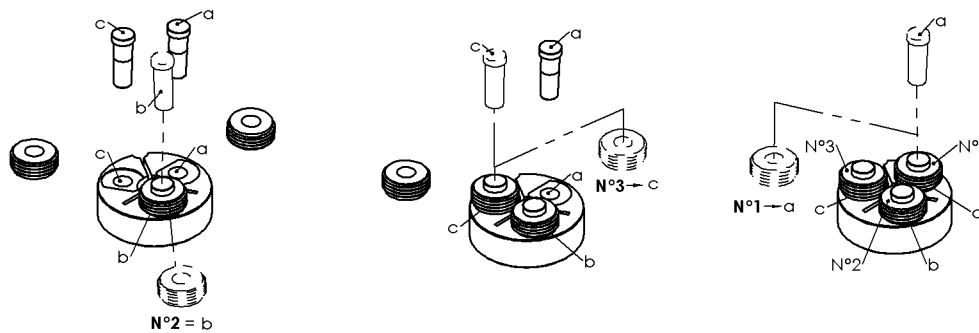

5.6.2 L.h. threads and double pitch r.h.

Identical proceeding as for point 5.6.1, but the order of the rollers No 1, 2 and 3 is reversed (anti-clock direction).

Remark

When dismantling and assembling the rollers, it is advised to put always the same studs into the same holes. The aim is to avoid that for tolerance's reasons one stud would get less tight than the other. We advise therefore to mark out the studs in relation to their bores, before taking them out.

6 SPARE PARTS

When ordering spare parts, please indicate:

6.1 Thread rolling die

Only rollers can be supplied and only for adjustable dies.

- Adjustable rolling die: - type of die (dia. and pitch) RM 2.00 x 0.25
- designation 1 set of rollers
- Non-adjustable die: - no spare parts can be supplied for this die type.

6.2 Die holder

Die holder: - Type of die holder Die holder R 25-8
- designation 1 nut

7 STARTING CAM (for cam controlled machines)

7.1 Working angle of the engaging cam

To get the best use of Habegger thread rolling dies, the working angle of the engaging cam must be calculated. The compensation spring of the threading spindle must be taken off. The start angle can be cut with a file. It is calculated as follows:

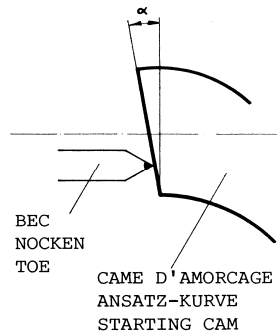

For lever ratio 1:1

V = Difference of RPM between headstock spindle and attachment spindle

P = Pitch of the workpiece, in mm

n = Production (number of parts per minute)

d = Diameter of the starting cam in mm.

$$\text{Formula : } \frac{V \cdot P}{n \cdot d \cdot \pi} = \text{tg } \alpha$$

7.2 Practical example:

Headstock speed: 5000 min⁻¹

Speed of attachment spindle: 6000 min⁻¹

Production: 3 pieces/min

Diameter of starting cam: 95 mm

Pitch of workpiece: 0.5 mm

$$\frac{V \cdot P}{n \cdot d \cdot \pi} = \frac{(6000-5000) \cdot 0.5}{3 \cdot 95 \cdot \pi} = \frac{500}{895.3} = \text{tg } 0.558 = 29.2^\circ$$

7.3 Machining of the cam

To make machining the cam easier, we can represent the triangle on a squared paper. Cut off the triangle and report it on the cam to mark out the angle.

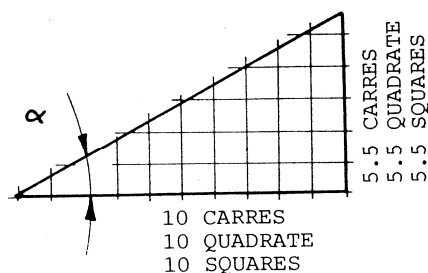

8 DIFFICULT ENGAGING START

If the start is difficult or if the slope on the cam is too fast, causing the deflection of the levers and a bad engaging of the die, the engaging thrust must be parted off between headstock feed and starting cam.

V = Difference of RPM between headstock spindle and attachment spindle

P = Pitch of the workpiece, in mm

n = Production (number of parts per minute)

d = Diameter of the starting cam in mm

Example: V = 1000 min⁻¹
P = 0.5 mm
n = 2 pieces/minute
d = 95 mm

$$\frac{1000 \cdot 0.5}{2 \cdot 95 \cdot \pi} = \frac{500}{596.9} = \text{tg } 0.838 = 39.95^\circ$$

That slope is too fast. We part it off as follows:

Example: VS (headstock speed) : 5000 min⁻¹
C (headstock feed) : 0.05 mm/rev.

Totale feed	: V · P	= 1000 · 0.5	= 500 mm
Headstock feed	: VS · C	= 5000 · 0.05	= 250 mm

Difference of the feeds : 500 - 250 = 250 mm

$$\text{Headstock cam} : \frac{250}{2 \cdot 95 \cdot \pi} = \text{tg } 0.419 = 22.7^\circ$$

$$\text{Starting cam} : \frac{250}{2 \cdot 95 \cdot \pi} = \text{tg } 0.419 = 22.7^\circ$$