

Alouette Tool Co Live Tool Catalog



star

CITIZEN



TSUGAMI
SWISS



Switek
Machinery America



GANESH
MACHINERY



NOMURA



Hanwha



NEXTURN
SWISS TURN LEADER



NAKAMURA

DOOSAN



Contents

STAR	01~10
TSUGAMI	11~17
CITIZEN	18~26
MIYANO	27~30
GANESH	31~33
NOMURA	34~36
HANWHA	37~39
SWISTEK	40~48
DOOSAN	49
NAKAMURA	50
NEXTURN	51

STAR

ECAS, SB, SR, SW

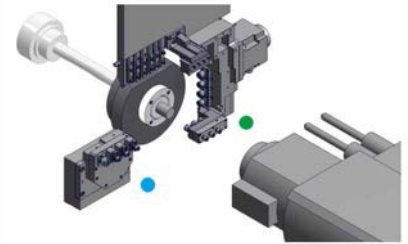

STAR

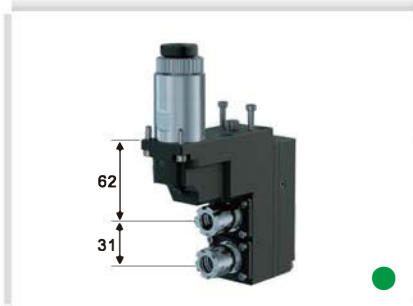

2-spindle drilling/milling unit

Product No.	STRA2A2204
Ref. No.	54151 STR446200
Speed ratio	1:1
RPM Max.	6000
Tool clamping	ER16M

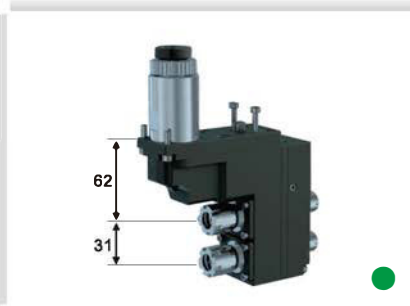

2-spindle double drilling/milling unit

Product No.	STRA2B2202
Ref. No.	66159 STR546200
Speed ratio	1:1
RPM Max.	6000
Tool clamping	ER16M/ER11M

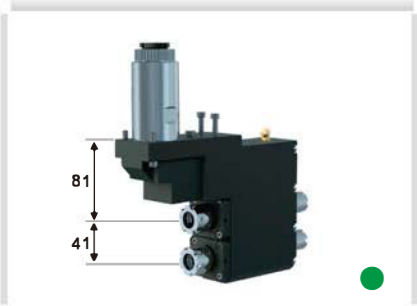

2-spindle double drilling/milling unit

Product No.	STRA2B2302
Ref. No.	10169 STJA5N22000
Speed ratio	1:1
RPM Max.	5000
Tool clamping	ER20M/ER16M

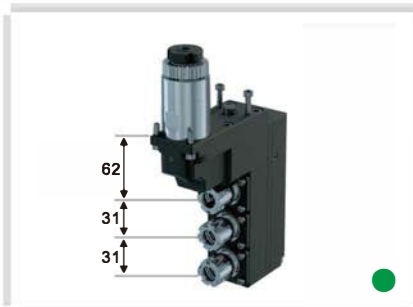

3-spindle drilling/milling unit

Product No.	STRA2A3201
Ref. No.	66151 STR446300
Speed ratio	1:1
RPM Max.	6000
Tool clamping	ER16M



3-spindle drilling/milling unit

Product No.	STRA2A3301
Ref. No.	67151 STR446300-1
Speed ratio	1:1
RPM Max.	6000
Tool clamping	ER16M

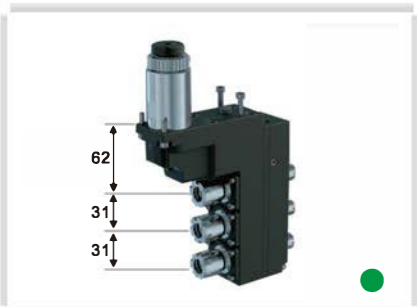

3-spindle double drilling/milling unit

Product No.	STRA2B3201
Ref. No.	67161 STR546300
Speed ratio	1:1
RPM Max.	6000
Tool clamping	ER16M/ER11M



3-spindle double drilling/milling unit

Product No.	STRA2B3301
Ref. No.	67159 STR546300-1
Speed ratio	1:1
RPM Max.	6000
Tool clamping	ER16M/ER11M

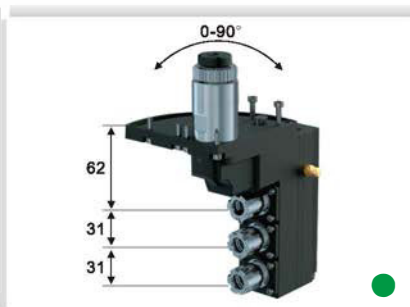

3-spindle drilling/milling unit ↕

Product No.	STRA2A3202
Ref. No.	— STR496300
Speed ratio	1:1
RPM Max.	6000
Tool clamping	ER16M

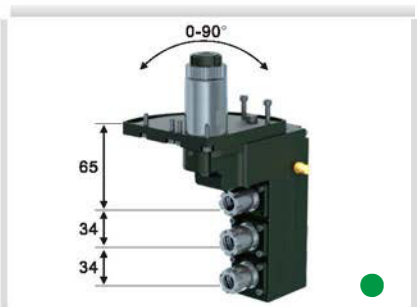

3-spindle drilling/milling unit ↕

Product No.	STRA2A3302
Ref. No.	— STR496300-1
Speed ratio	1:1
RPM Max.	6000
Tool clamping	ER16M

STAR

ECAS, SB, SR, SW

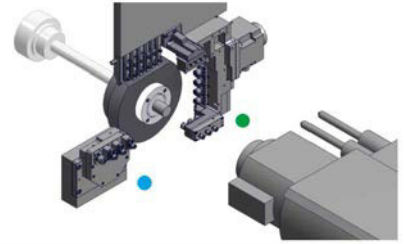

STAR



2-spindle drilling/milling unit ⚙️

Product No.	STRA2A2202
Ref. No.	— STR496200
Speed ratio	1:1
RPM Max.	6000
Tool clamping	ER16M

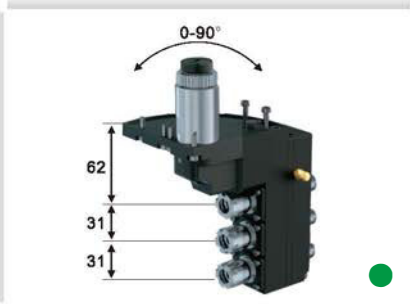

3-spindle double drilling/milling unit ⚙️

Product No.	STRA2B3202
Ref. No.	— STR596300
Speed ratio	1:1
RPM Max.	6000
Tool clamping	ER16M/ER11M

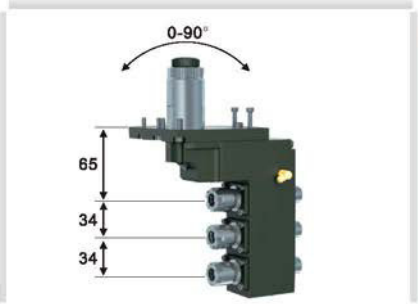

3-spindle double drilling/milling unit ⚙️

Product No.	STRA2B3302
Ref. No.	— STR596300-1
Speed ratio	1:1
RPM Max.	6000
Tool clamping	ER16M/ER11M

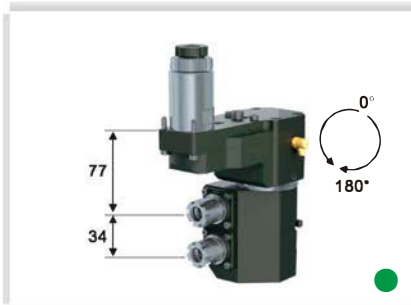

2-spindle drilling/milling unit ⚙️

Product No.	STRA2A2303
Ref. No.	— STR496200-2
Speed ratio	1:1
RPM Max.	6000
Tool clamping	ER16M

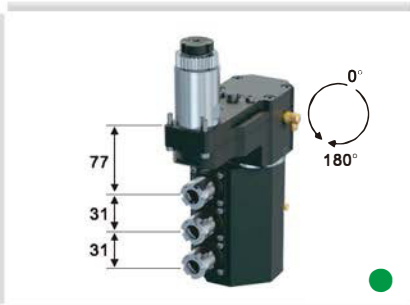

3-spindle drilling/milling unit ⚙️

Product No.	STRA2A3203
Ref. No.	— STR496300-2
Speed ratio	1:1
RPM Max.	6000
Tool clamping	ER16M

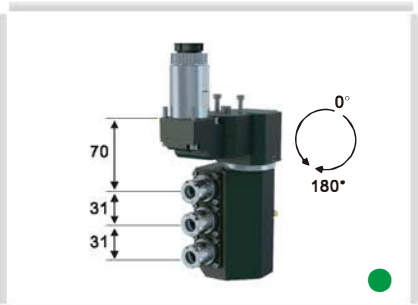

3-spindle drilling/milling unit ⚙️

Product No.	STRA2A3207
Ref. No.	— STR496300-5
Speed ratio	1:1
RPM Max.	6000
Tool clamping	ER16M



Cross drilling/milling unit

Product No.	STRA116202 / STRA120201
Ref. No.	33150 STR161000
Speed ratio	1:1
RPM Max.	8000
Tool clamping	ER16M / ER20M



Cross drilling/milling unit

Product No.	STRA116201
Ref. No.	57155 STR166100
Speed ratio	1:1
RPM Max.	8000
Tool clamping	ER16M



Cross drilling/milling unit

Product No.	STRA111202
Ref. No.	— STR161100
Speed ratio	1:3 ⬆️
RPM Max.	18000
Tool clamping	ER11A

STAR

ECAS, SB, SR, SW

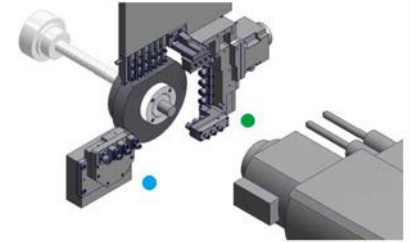

STAR



Cross drilling/milling unit, 3-spindle

Product No.	STRA111201
Ref. No.	— STR261300
Speed ratio	1:1
RPM Max.	8000
Tool clamping	ER11M



Slotting unit

Product No.	STRA712201
Ref. No.	54153 STR301000
Speed ratio	1:0.374 ↓
RPM Max.	4000
Tool clamping	Ø12.7xØ50



Thread whirling unit ⬆

Product No.	STRA545203
Ref. No.	68172 STR260100N
Speed ratio	1:1
RPM Max.	6000
Tool clamping	Utilis no.119287



※Option: cutter

Polygon unit

Product No.	STRA400201
Ref. No.	54191 STR150100
Speed ratio	1:1
RPM Max.	3000
Tool clamping	—



Gear hobbing unit ⬆

Product No.	STRA613201
Ref. No.	— STR130100
Speed ratio	1:1
RPM Max.	6000
Tool clamping	Ø13xØ30x20



Idler shaft

Product No.	STRA100000
Ref. No.	57189 STR160000
Speed ratio	—
RPM Max.	—
Tool clamping	—



Boring bar holder

Product No.	STRA803307
Ref. No.	— STR14036200
Speed ratio	—
RPM Max.	—
Tool clamping	Ø22



Air tool holder ⬆

Product No.	STRA0002
Ref. No.	— STR210300
Speed ratio	—
RPM Max.	—
Tool clamping	Ø22



Air tool holder

Product No.	STBA0004
Ref. No.	— STB410100
Speed ratio	—
RPM Max.	—
Tool clamping	Ø22

STAR

ECAS, SB, SR, SW

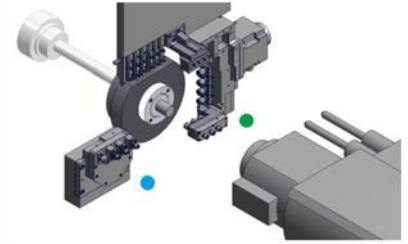

STAR



Air tool holder for sub spindle

Product No.	STRB0001	
Ref. No.	–	STR14036200
Speed ratio	–	
RPM Max.	–	
Tool clamping	Ø22.8	



Slotting unit for sub spindle ⚙️

Product No.	STRB700201	
Ref. No.	69166/69165	STR731000
Speed ratio	1:0.55 ↓	
RPM Max.	4000	
Tool clamping	Ø5/6/8/10/12.7/13xØ50	



Slotting unit for sub spindle ⚙️

Product No.	STRB700202	
Ref. No.	0R165	STR731000-1
Speed ratio	1:0.55 ↓	
RPM Max.	4000	
Tool clamping	Ø5/6/8/10/12.7/13xØ50	



Drilling/milling unit for sub spindle

Product No.	STRB111208	
Ref. No.	54161	STR711000
Speed ratio	1:1	
RPM Max.	6000	
Tool clamping	ER11M	



Drilling/milling unit for sub spindle

Product No.	STRB116202	
Ref. No.	57161	STR761000
Speed ratio	1:1	
RPM Max.	6000	
Tool clamping	ER16M	



Drilling/milling unit for sub spindle

Product No.	STRB116201	
Ref. No.	0R161	STR766100
Speed ratio	1:1	
RPM Max.	6000	
Tool clamping	ER16M	



Drilling/milling unit for sub spindle

Product No.	STRB111204	
Ref. No.	–	STR761200
Speed ratio	1:3 ↑	
RPM Max.	18000	
Tool clamping	ER11	



Drilling/milling unit for sub spindle, 3-spindle

Product No.	STRB108101	
Ref. No.	–	STR748400
Speed ratio	1:1	
RPM Max.	8000	
Tool clamping	ER8M	



Drilling/milling unit for sub spindle, 3-spindle

Product No.	STRB111201	
Ref. No.	0E151	STR741300
Speed ratio	1:1	
RPM Max.	8000	
Tool clamping	ER11M	

STAR

ECAS, SB, SR, SW

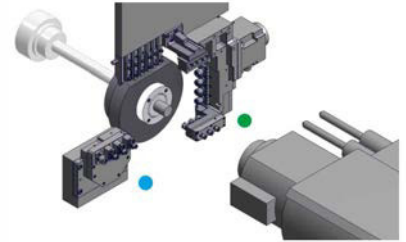

STAR



Drill holder for sub spindle

Product No.	STRB81Q309
Ref. No.	— STR646100-1
Speed ratio	—
RPM Max.	—
Tool clamping	ER16M



Drill holder for sub spindle

Product No.	STRB81Q307
Ref. No.	54121 STR646100-5
Speed ratio	—
RPM Max.	—
Tool clamping	ER16M



Drill holder for sub spindle ^{IC} 25bar

Product No.	STRB81Q304
Ref. No.	— STR646100-2
Speed ratio	—
RPM Max.	—
Tool clamping	ER16M



Drill holder for sub spindle

Product No.	STRB81Q305
Ref. No.	— STR642100
Speed ratio	—
RPM Max.	—
Tool clamping	ER20M



Drill holder for sub spindle

Product No.	STRB81Q313
Ref. No.	67122 STR642100-3
Speed ratio	—
RPM Max.	—
Tool clamping	ER20M



Drill holder for sub spindle ^{IC} 25bar

Product No.	STRB81Q303
Ref. No.	— STR642100-1
Speed ratio	—
RPM Max.	—
Tool clamping	ER20M



Drill holder for sub spindle

Product No.	STRB81E201
Ref. No.	OR122 STR646100-3
Speed ratio	—
RPM Max.	—
Tool clamping	ER16M



Drill holder for sub spindle ^{IC} 25bar

Product No.	STRB81E202
Ref. No.	OR123 STR646100-4
Speed ratio	—
RPM Max.	—
Tool clamping	ER16M



Drill holder for sub spindle

Product No.	STRB81S301
Ref. No.	10119 STJA22KBA00
Speed ratio	—
RPM Max.	—
Tool clamping	ER20M



STAR

ECAS, SB, SR, SW

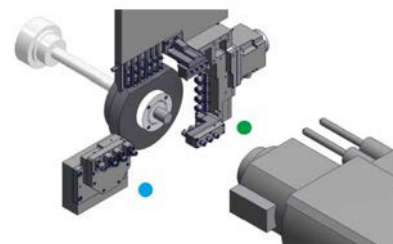

STAR



Drill holder for sub spindle

Product No.	STRB81Q101
Ref. No.	69125 STR64110010J
Speed ratio	–
RPM Max.	–
Tool clamping	ER11M



Drill holder for sub spindle

Product No.	STRB81Q201
Ref. No.	– STR64110020R
Speed ratio	–
RPM Max.	–
Tool clamping	ER11M



※ER drill holder not included

Drill holder for sub spindle

Product No.	STRB82Q201
Ref. No.	– STJ640100
Speed ratio	–
RPM Max.	–
Tool clamping	Ø16



※ER drill holder not included

Drill holder for sub spindle

Product No.	STRB82Q202
Ref. No.	– STJ640200
Speed ratio	–
RPM Max.	–
Tool clamping	Ø16



Boring bar holder for sub spindle

Product No.	STRB82Q200
Ref. No.	– STR601000
Speed ratio	–
RPM Max.	–
Tool clamping	Ø3/4/5/6/8/9/10/12/16



Boring bar holder for sub spindle

Product No.	STRBA22000+COMBAB0000
Ref. No.	– STR601200
Speed ratio	–
RPM Max.	–
Tool clamping	Ø3/4/5/6/8/9/10/12/16



Boring bar holder for sub spindle

Product No.	STRB82E200
Ref. No.	– STR680100-4
Speed ratio	–
RPM Max.	–
Tool clamping	Ø6/8/9/10/12/16

STAR

ECAS, SB, SR, SW

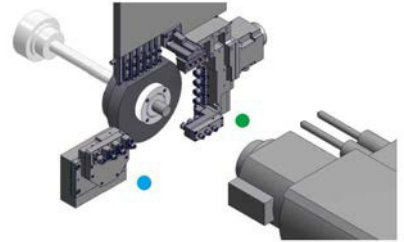

STAR



Turning holder for sub spindle

Product No.	✚ STRBA22000+COMBADL550
Ref. No.	— STR620100-1
Speed ratio	—
RPM Max.	—
Tool clamping	DC.T11T3



Turning holder for sub spindle ✚

Product No.	STRBA22000+COMBADR550
Ref. No.	— STR620100-6
Speed ratio	—
RPM Max.	—
Tool clamping	DC.T11T3



Turning holder for sub spindle ✚

Product No.	STRBA22000+COMBADL350
Ref. No.	— STR620100-7
Speed ratio	—
RPM Max.	—
Tool clamping	VC.T1103



Turning holder for sub spindle

Product No.	STRB912201
Ref. No.	— STR620100-3
Speed ratio	—
RPM Max.	—
Tool clamping	Ø12



Turning holder for sub spindle

Product No.	STRB910202
Ref. No.	— STR620100-4
Speed ratio	—
RPM Max.	—
Tool clamping	□10



Turning holder for sub spindle ✚

Product No.	STRBA22000+COMBAC1000
Ref. No.	— STR620100-2
Speed ratio	—
RPM Max.	—
Tool clamping	□10



Turning holder for sub spindle

Product No.	STRB910201
Ref. No.	— STR620100
Speed ratio	—
RPM Max.	—
Tool clamping	□10



Turning holder for sub spindle

Product No.	STRB912203
Ref. No.	— STR62011200
Speed ratio	—
RPM Max.	—
Tool clamping	□12



Turning holder for sub spindle

Product No.	STRB912204
Ref. No.	— STR62011200-1
Speed ratio	—
RPM Max.	—
Tool clamping	□12

STAR

SV32JII, SV12, SV20, ECAS20T

STAR



Axial drilling/milling unit

Product No.	STVC116201	
Ref. No.	22150	STV10301600
Speed ratio	1:1	
RPM Max.	6000	
Tool clamping	ER16A	



Radial drilling/milling unit

Product No.	STVC2B2201	
Ref. No.	42159	STV51200
Speed ratio	1:1.16 	
RPM Max.	6000	
Tool clamping	ER11M	



Thread whirling unit 

Product No.	STVC545201	
Ref. No.	–	STV260100
Speed ratio	1:1	
RPM Max.	6000	
Tool clamping	Utilis no.119287	



※Longitudinally adj. ±1mm

Turning holder 

Product No.	STVC916201	
Ref. No.	–	STV901000
Speed ratio	–	
RPM Max.	–	
Tool clamping	□16	



※Longitudinally adj. ±1mm

Turning holder 

Product No.	STVC916202	
Ref. No.	–	STV901000-1
Speed ratio	–	
RPM Max.	–	
Tool clamping	□16	



Boring bar holder

Product No.	STVC801204	
Ref. No.	–	STV140100-1
Speed ratio	–	
RPM Max.	–	
Tool clamping	Ø32	

STAR

SV32, ECAS32T, SV-38R

STAR



Axial drilling/milling unit

Product No.	STVC120301	
Ref. No.	58151	STV10302000-1
Speed ratio	1:1	
RPM Max.	6000	
Tool clamping	ER20A	



Axial drilling/milling unit

Product No.	STVC116301	
Ref. No.	43151	STEV2A1C26A00
Speed ratio	1:1	
RPM Max.	6000	
Tool clamping	ER16A	



Radial drilling/milling unit

Product No.	STVC2B2301	
Ref. No.	—	STV51200-1
Speed ratio	1:1.16 	
RPM Max.	6000	
Tool clamping	ER11M	



Thread whirling unit 

Product No.	STVC545301	
Ref. No.	—	STV260100-1
Speed ratio	1:1	
RPM Max.	6000	
Tool clamping	Utilis no.119287	

SG42



Radial drilling/milling unit (for sub spindle)

Product No.	STGC2A2401	
Ref. No.	—	STG42042073200
Speed ratio	1:1	
RPM Max.	6000	
Tool clamping	ER20M	



Radial drilling/milling unit (for main spindle)

Product No.	STGC2A2402	
Ref. No.	—	STG42042073200-1
Speed ratio	1:1	
RPM Max.	6000	
Tool clamping	ER20M	

TSUGAMI

BO205

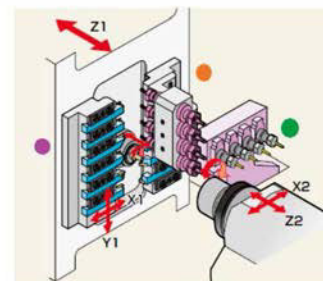

TSUGAMI



Thread whirling unit

Product No.	TSBA545201
Ref. No.	— TSCA3L01000
Speed ratio	1:1
RPM Max.	8000
Tool clamping	Utilis no.119287



Tool holder

Product No.	TSBA0001
Ref. No.	3220-T520 TSB140400
Speed ratio	—
RPM Max.	—
Tool clamping	Ø20



Cross drilling/milling unit for sub spindle

Product No.	TSBB311201
Ref. No.	3220-Y7074 TSB861100
Speed ratio	1:1
RPM Max.	8000
Tool clamping	ER11A



Drilling/milling unit for sub spindle

Product No.	TSBB116201
Ref. No.	3220-Y7072 TSB746100-1
Speed ratio	1:1
RPM Max.	8000
Tool clamping	ER16M



Drill holder for sub spindle

Product No.	TSBB81Q202
Ref. No.	—
Speed ratio	—
RPM Max.	—
Tool clamping	ER11A



Drill holder for sub spindle

Product No.	TSBB82Q201
Ref. No.	3220-Y7073 TSB640100-2
Speed ratio	—
RPM Max.	—
Tool clamping	Ø20



Turning holder for sub spindle

Product No.	TSBBA20000+COMBADL550
Ref. No.	TSCA41YAA00
Speed ratio	—
RPM Max.	—
Tool clamping	DC.T11T3



Air tool holder for sub spindle

Product No.	TSBB0001
Ref. No.	TSB601000
Speed ratio	—
RPM Max.	—
Tool clamping	NR-303

TSUGAMI

BO265, BO266, BO325, BO326, BO385



TSUGAMI



Cross drilling/milling unit

Product No.	TSBA116301	
Ref. No.	3268-T051	TSB246100
Speed ratio	1:1	
RPM Max.	6000	
Tool clamping	ER16A	



Cross drilling/milling unit

Product No.	TSBA120301	
Ref. No.	3268-T051-ER20	TSB242100
Speed ratio	1:1	
RPM Max.	6000	
Tool clamping	ER20A	



Cross drilling/milling unit

Product No.	TSBA111301	
Ref. No.	3290-Y670	TSB241100
Speed ratio	1:2	
RPM Max.	12000	
Tool clamping	ER11A	



Cross drilling/milling unit

Product No.	TSBA116303	
Ref. No.	—	TSB246100-1
Speed ratio	1:1	
RPM Max.	6000	
Tool clamping	ER16A	



Cross drilling/milling unit, 2-spindle

Product No.	TSBA116304	
Ref. No.	—	TSB246200
Speed ratio	1:1	
RPM Max.	6000	
Tool clamping	ER16A	



Thread whirling unit

Product No.	TSBA545301	
Ref. No.	3268-Y450	TSB260100
Speed ratio	1:1	
RPM Max.	5000	
Tool clamping	Utilis no.119287	



Drilling unit (deep hole)

Product No.	TSBA116302	
Ref. No.	3290-Y010	TSB146200
Speed ratio	1:1	
RPM Max.	8000	
Tool clamping	ER16A	



2-spindle drilling/milling unit

Product No.	TSBA2A2304	
Ref. No.	—	TSB446200-1
Speed ratio	1:1	
RPM Max.	6000	
Tool clamping	ER16AM	



2-spindle double drilling/milling unit

Product No.	TSBA2B2303	
Ref. No.	3282-Y901	TSB546200-1
Speed ratio	1:1	
RPM Max.	6000	
Tool clamping	ER16AM	

TSUGAMI

BO265, BO266, BO325, BO326, BO385



TSUGAMI



2-spindle drilling/milling unit ⚙️

Product No.	TSBA2A2301
Ref. No.	— TSB496200
Speed ratio	1:1
RPM Max.	6000
Tool clamping	ER16AM



2-spindle double drilling/milling unit ⚙️

Product No.	TSBA2B2302
Ref. No.	3282-Y921 TSB596200
Speed ratio	1:1
RPM Max.	6000
Tool clamping	ER16AM



Drilling/milling unit

Product No.	TSBA2A1301
Ref. No.	— TSB446100-1
Speed ratio	1:1
RPM Max.	6000
Tool clamping	ER16AM



3-spindle drilling/milling unit

Product No.	TSBA2A3301
Ref. No.	— TSGA4N6300
Speed ratio	1:1
RPM Max.	5000
Tool clamping	ER16AM



3-spindle double drilling/milling unit

Product No.	TSBA2B3302
Ref. No.	— TSB541300
Speed ratio	1:1
RPM Max.	6000
Tool clamping	ER11A

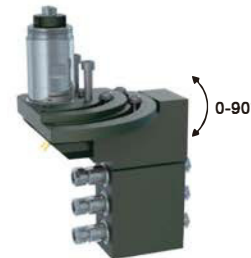

3-spindle double drilling/milling unit ⚙️

Product No.	TSBA2B3301
Ref. No.	— TSB591300
Speed ratio	1:1
RPM Max.	6000
Tool clamping	ER11A



Drilling/milling unit for sub spindle

Product No.	TSBB116301
Ref. No.	3282-Y041 TSB746100
Speed ratio	1:1
RPM Max.	6000
Tool clamping	ER16A



Drilling/milling unit for sub spindle

Product No.	TSBB11301
Ref. No.	3290-Y680 TSB741100
Speed ratio	1:2 ⬆️
RPM Max.	12000
Tool clamping	ER11A



Cross drilling/milling unit for sub spindle

Product No.	TSBB316301
Ref. No.	3290-Y041 TSB866100
Speed ratio	1:1
RPM Max.	6000
Tool clamping	ER16M

TSUGAMI

BO265, BO266, BO325, BO326, BO385



TSUGAMI

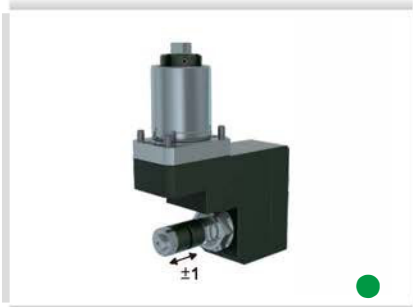

Slotting unit for sub spindle 

Product No.	TSBB712301
Ref. No.	– TSB730100
Speed ratio	1:1
RPM Max.	3000
Tool clamping	Ø12.7xØ70



Drill holder for sub spindle  25bar

Product No.	TSBB82Q304
Ref. No.	3282-Y211 TSB640100MC
Speed ratio	–
RPM Max.	–
Tool clamping	Ø25



Drill holder for sub spindle

Product No.	TSBB82Q303
Ref. No.	– TSB640100MC
Speed ratio	–
RPM Max.	–
Tool clamping	Ø25



Drill holder for sub spindle

Product No.	TSBB82Q302
Ref. No.	– TSB640100-1
Speed ratio	–
RPM Max.	–
Tool clamping	Ø25



Drill holder for sub spindle  25bar

Product No.	TSBB81Q301
Ref. No.	– TSB642100
Speed ratio	–
RPM Max.	–
Tool clamping	ER20M



Turning holder for sub spindle

Product No.	TSBB912301
Ref. No.	– TSB620100
Speed ratio	–
RPM Max.	–
Tool clamping	□12



Turning holder for sub spindle

Product No.	TSBB910301
Ref. No.	– TSB620100-1
Speed ratio	–
RPM Max.	–
Tool clamping	□10



Turning holder for sub spindle

Product No.	TSBB912302
Ref. No.	– TSB620100-2
Speed ratio	–
RPM Max.	–
Tool clamping	□12



Boring bar holder for sub spindle 

Product No.	TSBBA42000+COMBAB0000
Ref. No.	– TSGA43HKA00
Speed ratio	–
RPM Max.	–
Tool clamping	Ø3/4/5/6/8/9/10/12/16

TSUGAMI

S205, S206

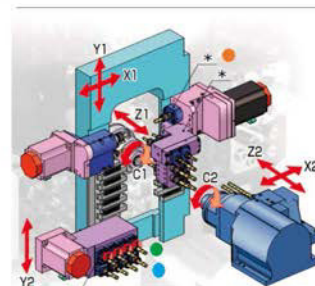

Cross drilling/milling unit

Product No.	TSSA116201	
Ref. No.	3281-T050	TSS161000
Speed ratio	1:1	
RPM Max.	8000	
Tool clamping	ER16M	



2-spindle double drilling/milling unit

Product No.	TSSA2B2201	
Ref. No.	3281-Y240	TSS562000
Speed ratio	1:1	
RPM Max.	8000	
Tool clamping	ER16M/ER11A	

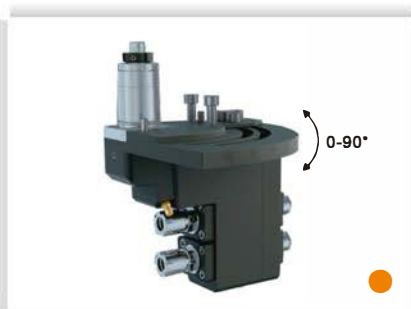

2-spindle double drilling/milling unit

Product No.	TSSA2B2202	
Ref. No.	3281-Y280	TSS562100
Speed ratio	1:1	
RPM Max.	8000	
Tool clamping	ER16M/ER11A	



3-spindle drilling/milling unit

Product No.	TSSA2A3201	
Ref. No.	—	TSS441300
Speed ratio	1:1	
RPM Max.	8000	
Tool clamping	ER11A	



3-spindle drilling/milling unit

Product No.	TSSA2A3202	
Ref. No.	—	TSS446300
Speed ratio	1:1	
RPM Max.	8000	
Tool clamping	ER16A	



3-spindle double drilling/milling unit

Product No.	TSSA2B3201	
Ref. No.	—	TSS546300
Speed ratio	1:1	
RPM Max.	8000	
Tool clamping	ER16A/ER11A	



3-spindle drilling/milling unit

Product No.	TSSA2A3203	
Ref. No.	—	TSS496300
Speed ratio	1:1	
RPM Max.	8000	
Tool clamping	ER16A	

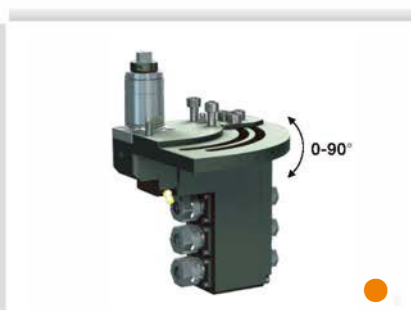

3-spindle double drilling/milling unit

Product No.	TSSA2B3202	
Ref. No.	—	TSS596300
Speed ratio	1:1	
RPM Max.	8000	
Tool clamping	ER16A/ER11A	



Thread whirling unit

Product No.	TSSA545201	
Ref. No.	3281-Y450	TSS260100
Speed ratio	1:1	
RPM Max.	5000	
Tool clamping	Utilis no.119287	

TSUGAMI

S205, S206

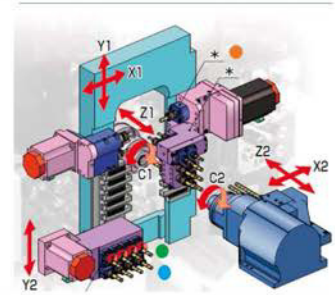

Cross drilling/milling unit for sub spindle

Product No.	TSSB316201	
Ref. No.	3281-Y460	TSS861000
Speed ratio	1:1	
RPM Max.	6000	
Tool clamping	ER16M	



Drilling/milling unit for sub spindle

Product No.	TSSB116201	
Ref. No.	3281-S080	TSS761000
Speed ratio	1:1	
RPM Max.	8000	
Tool clamping	ER16M	



Drill holder for sub spindle

Product No.	TSSB82Q202 / TSSB82Q205	
Ref. No.	3281-S060	TSS601000 / TSS640100-1
Speed ratio	-	
RPM Max.	-	
Tool clamping	Ø20 / Ø16	



Drill holder for sub spindle **ic** 25bar

Product No.	TSSB81Q202	
Ref. No.	-	TSS646100
Speed ratio	-	
RPM Max.	-	
Tool clamping	ER16M	



Drill holder for sub spindle **ic** 25bar

Product No.	TSSB81Q201	
Ref. No.	-	TSS642100
Speed ratio	-	
RPM Max.	-	
Tool clamping	ER20M	



Drill holder for sub spindle

Product No.	TSSB82Q203	
Ref. No.	-	TSS601100
Speed ratio	-	
RPM Max.	-	
Tool clamping	Ø20	



Turning holder for sub spindle

Product No.	TSSB912201	
Ref. No.	-	TSS620100
Speed ratio	-	
RPM Max.	-	
Tool clamping	□12	



Turning holder for sub spindle

Product No.	TSSB910201	
Ref. No.	-	TSS620100-1
Speed ratio	-	
RPM Max.	-	
Tool clamping	□10	



Turning holder for sub spindle

Product No.	TSSB910202	
Ref. No.	-	TSS620100-2
Speed ratio	-	
RPM Max.	-	
Tool clamping	□10	

TSUGAMI

TSUGAMI

M06, M08

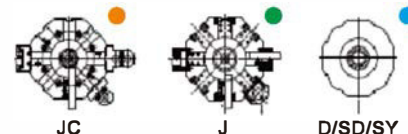

Axial drilling/milling unit

Product No.	TSMC125001	
Ref. No.	3295-Z92511-0101	TSIM2A1A15100
Speed ratio	1:1	
RPM Max.	6000	
Tool clamping	ER25UM	



Radial drilling/milling unit

Product No.	TSMC2A2001	
Ref. No.	—	TSIA2B1A12200
Speed ratio	1:1	
RPM Max.	5000	
Tool clamping	ER20A	



Turning holder (cut-off)

Product No.	TSMC925001	
Ref. No.	3295-H260	
Speed ratio	—	TSLM60BA11A00
RPM Max.	—	
Tool clamping	□25	



Turning holder

Product No.	TSMC925002	
Ref. No.	3295-H210	
Speed ratio	—	TSLM50BA22A00
RPM Max.	—	
Tool clamping	□25	



Boring bar holder

Product No.	TSMC801001	
Ref. No.	3295-H202	
Speed ratio	—	TSM040100
RPM Max.	—	
Tool clamping	Ø32	



Boring bar holder

Product No.	TSMC802001	
Ref. No.	—	
Speed ratio	—	TSM040200
RPM Max.	—	
Tool clamping	Ø25	



Boring bar holder

Product No.	TSMC802004	
Ref. No.	3297-H020	
Speed ratio	—	TSM040200-3
RPM Max.	—	
Tool clamping	Ø25	



Boring bar holder (offset, for main spindle)

Product No.	TSMC802003	
Ref. No.	3295-H270	
Speed ratio	—	TSM040200-225
RPM Max.	—	
Tool clamping	Ø25	



Boring bar holder (offset, for sub spindle)

Product No.	TSMC802002	
Ref. No.	3295-H280	
Speed ratio	—	TSM040200-125
RPM Max.	—	
Tool clamping	Ø25	



Boring bar holder (offset, for sub spindle)

Product No.	TSMC802007	
Ref. No.	—	
Speed ratio	—	TSM040200-125(40)
RPM Max.	—	
Tool clamping	Ø25	

CITIZEN

M32



Axial drilling/milling unit

Product No.	CTMC116302	
Ref. No.	KSC110	CTM3204161100
Speed ratio	1:1	
RPM Max.	5000	
Tool clamping	ER16A	



Axial drilling/milling unit

Product No.	CTMC116301	
Ref. No.	KSC110-2X	CTM3204161100-1
Speed ratio	1:2	
RPM Max.	10000	
Tool clamping	ER16A	



Radial drilling/milling unit

Product No.	CTMC2A1301	
Ref. No.	KSE110	CTM3204162100
Speed ratio	1:1	
RPM Max.	6000	
Tool clamping	ER16A	



Radial drilling/milling unit

Product No.	CTMC2A1302	
Ref. No.	KSE310	CTM3204162100-1
Speed ratio	1:1	
RPM Max.	6000	
Tool clamping	ER16A	

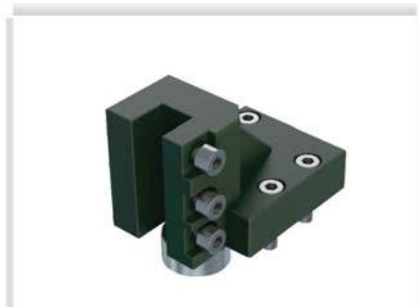

Turning holder

Product No.	CTMC916301	
Ref. No.	CTF116	CTM901000
Speed ratio	-	
RPM Max.	-	
Tool clamping	□ 16	



Boring bar holder

Product No.	CTMC801301	
Ref. No.	CDF101	CTM101000
Speed ratio	-	
RPM Max.	-	
Tool clamping	Ø25.4	



Boring bar holder

Product No.	CTMC802301	
Ref. No.	CDF401	CTM102000
Speed ratio	-	
RPM Max.	-	
Tool clamping	Ø25.4	

CITIZEN

M16



Axial drilling/milling unit

Product No.	CTMC111102
Ref. No.	MSC107BT CTM1605111100-1
Speed ratio	1:1
RPM Max.	6000
Tool clamping	ER11A



Axial drilling/milling unit

Product No.	CTMC111101
Ref. No.	MSC106 CTM1605111100
Speed ratio	1:1
RPM Max.	6000
Tool clamping	ER11A



Axial drilling/milling unit

Product No.	CTMC111103
Ref. No.	MSC407 CTM1605111200
Speed ratio	1:1
RPM Max.	6000
Tool clamping	ER11A



Radial drilling/milling unit

Product No.	CTMC2A1102
Ref. No.	MSE106 CTM1604112100
Speed ratio	1:1
RPM Max.	4000
Tool clamping	ER11A



Radial drilling/milling unit

Product No.	CTMC2A1103
Ref. No.	MST306 CTM1603112100
Speed ratio	1:1
RPM Max.	3000
Tool clamping	ER11A



Slotting unit

Product No.	CTMC712101
Ref. No.	MSS345 CTM1606122100
Speed ratio	1:1
RPM Max.	4000
Tool clamping	Ø12.7xØ70



Turning holder

CTMC910101
VTF110
□ 10
CTM1601101100



Turning holder (cut-off)

CTMC910102
VTF1310
□ 10
CTM1602101100



Boring bar holder

CTMC801102
VDF201
Ø19.05
CTM1603192100



Boring bar holder

CTMC801101
VDF501
Ø19.05
CTM1603192100-1



Boring bar holder

CTMC802101
VDF401
Ø19.05
CTM1603192200

CITIZEN

L Series

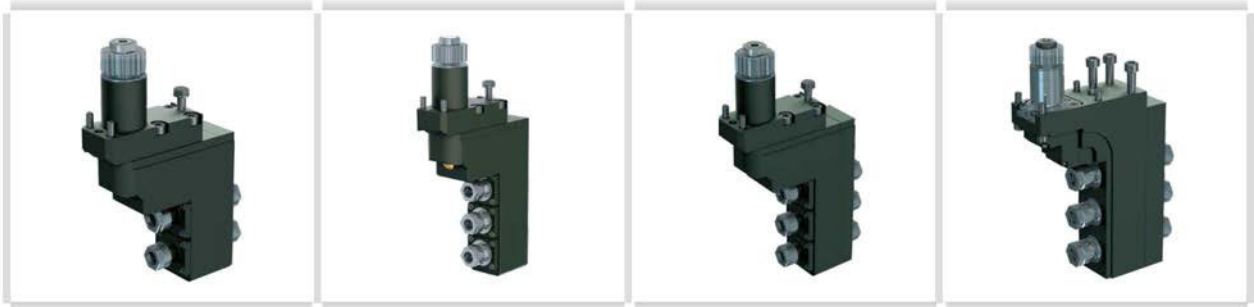



	2-spindle double drilling/milling unit	3-spindle drilling/milling unit	3-spindle double drilling/milling unit	3-spindle double drilling/milling unit
Product No.	CTLA2B2301	CTLA2A3301	CTLA2B3302	CTLA2B3301
Ref. No.	— CTA541200-1	BSE307/BSE407/BSE607	BSE507/BSE707	GSE1810
Speed ratio	1:1	1:1 CTA441300-1	1:1 CTA541300-1	1:1 CTL546300-32
RPM Max.	6000	6000	6000	6000
Tool clamping	ER11A	ER11A	ER11A	ER16AM



	2-spindle double drilling/milling unit	3-spindle double drilling/milling unit	2-spindle double drilling/milling unit	3-spindle double drilling/milling unit
Product No.	CTLA2B2201	CTLA2B3202	CTLA2B2202	CTLA2B3206
Ref. No.	GSE3107 CTL541200	GSE3207 CTL541300-2	GSE3707 CTL541200-1	GSE3807 CTL541300-3
Speed ratio	1:1	1:1	1:1	1:1
RPM Max.	6000	6000	6000	6000
Tool clamping	ER11A	ER11A	ER11A	ER11A



	Drilling/milling unit	3-spindle double drilling/milling unit 	Thread whirling unit 
Product No.	CTLA2A3202	CTLA2B3101	CTLA545201
Ref. No.	GSE3210 CTL160300	GSE3607 CTL591300-1	— CTL260100
Speed ratio	1:1	1:1	1:1
RPM Max.	—	8000	6000
Tool clamping	Ø31	ER11A	Utilis no.119287

CITIZEN

L Series

CITIZEN



	Drilling/milling unit		Double drilling/milling unit		Double drilling/milling unit		2-spindle drilling/milling unit	
Product No.	CTLA2A1201		CTLA2B1302		CTLA2B1201		CTLA2A2202	
Ref. No.	—	CTL411000	—	CTL541100	—	CTL511000	—	CTL441200
Speed ratio	1:1		1:3		1:1		1:1	
RPM Max.	6000		15000		6000		8000	
Tool clamping	ER11A		ER11A		ER11A/ER11M		ER11A	



	3-spindle drilling/milling unit		3-spindle double drilling/milling unit		3-spindle double drilling/milling unit		3-spindle drilling/milling unit	
Product No.	CTLA2A3204		CTLA2B3203		CTLA2B3204		CTLA2A3201	
Ref. No.	—	CTL441300	—	CTL541300-1	GSE1007	CTL541300	GSE910	CTAA4B63000
Speed ratio	1:1		1:1		1:1		1:1	
RPM Max.	8000		8000		4000		4000	
Tool clamping	ER11A		ER11A/ER11M		ER11A		ER16M	



	3-spindle double drilling/milling unit		Gear hobbing unit		Gear hobbing unit	
Product No.	CTLA2B3205		CTLA608202		CTLA608201	
Ref. No.	GSE1307	CTL513000-1	—	CTL130100-1	—	CTL130100
Speed ratio	1:1		1:1		1:1	
RPM Max.	4000		6000		6000	
Tool clamping	ER11A		Ø8xØ25x12		Ø8xØ25x12	

CITIZEN

L Series



Cross drilling/milling unit

Product No.	CTAA116201	
Ref. No.	GSC1310/GSC1110	CTA1661100
Speed ratio	1:1	
RPM Max.	7000	
Tool clamping	ER16AM	



Cross drilling/milling unit

Product No.	CTLA116201	
Ref. No.	GSC1210	CTL861000
Speed ratio	1:1	
RPM Max.	8000	
Tool clamping	ER16M	



Cross drilling/milling unit

Product No.	CTLA116203	
Ref. No.	GSC1210	CTL866100
Speed ratio	1:1	
RPM Max.	8000	
Tool clamping	ER16	



Cross drilling/milling unit

Product No.	CTLA116202	
Ref. No.	GSC510/GSC1010	CTL166100
Speed ratio	1:1	
RPM Max.	8000	
Tool clamping	ER16A	



Cross drilling/milling unit

Product No.	CTLA116301	
Ref. No.	GSC310	CTL166100-1
Speed ratio	1:1	
RPM Max.	8000	
Tool clamping	ER16A	



Cross drilling/milling unit

Product No.	CTLA111206	
Ref. No.	GSC507-3X	CTL161100-2
Speed ratio	1:3 	
RPM Max.	18000	
Tool clamping	ER11A	



Cross drilling/milling unit

Product No.	CTLA111208	
Ref. No.	GSE307	CTL141100
Speed ratio	1:1	
RPM Max.	5000	
Tool clamping	ER11A	



Cross drilling/milling unit

Product No.	CTLA111202	
Ref. No.	GSC907	CTL111000
Speed ratio	1:1	
RPM Max.	6000	
Tool clamping	ER11A	



Gear hobbing unit

Product No.	CTA608201	
Ref. No.	–	CTA130100
Speed ratio	1:1	
RPM Max.	3000	
Tool clamping	Ø8xØ25x15	

CITIZEN

L Series



Drilling/milling unit for sub spindle

Product No.	CTLB111202
Ref. No.	GSE3307/GSE3507/MSC507
Speed ratio	1:1 CTL711000
RPM Max.	8000
Tool clamping	ER11A



Cross drilling/milling unit for sub spindle

Product No.	CTLB311205
Ref. No.	GSS1330/GSS1430/GSS1530
Speed ratio	1:1 CTK861100
RPM Max.	6000
Tool clamping	ER11A



Cross drilling/milling unit for sub spindle

Product No.	CTLB316301
Ref. No.	GSE1910
Speed ratio	1:1 CTL866100-1
RPM Max.	6000
Tool clamping	ER16AM



Slotting unit for sub spindle

Product No.	CTLB700201
Ref. No.	— CTL731000
Speed ratio	1:1
RPM Max.	4000
Tool clamping	Ø6/12.7xØ35

CITIZEN

L Series



	Boring bar holder	Boring bar holder	Boring bar holder	Boring bar holder
Product No.	CTLA803305	CTLA803302	CTLA803303	CTLA802202
Ref. No.	GDF1601	—	—	GDF508 CTL140200-1
Speed ratio	— CTL14037800-25.4	—	—	—
RPM Max.	—	—	—	—
Tool clamping	Ø25.4	Ø19.05	Ø20	Ø19.05



	Boring bar holder	Boring bar holder	Boring bar holder	Boring bar holder
Product No.	CTLA801201	CTLA802201	CTLA803202	CTLA803203/CTLA803210
Ref. No.	GDF506 CTL101190	— CTL140200	— CTL140300	— CTL140300-2
Speed ratio	—	—	—	— CTL140300-6
RPM Max.	—	—	—	—
Tool clamping	Ø19.05	Ø19.05	Ø19.05	Ø19.05 / Ø20



	Boring bar holder	Boring bar holder	Boring bar holder	Boring bar holder
Product No.	CTLA803204/CTLA803206	CTLA803205	CTLA803101	CTLA803201
Ref. No.	GDF507 CTL140300-3	— CTL140300-8	— CTCA12JDA00	GDF607 CTL103000
Speed ratio	— CTL140300-10	—	—	—
RPM Max.	—	—	—	—
Tool clamping	Ø19.05 / Ø20	Ø20	Ø19.05	Ø19.05

CITIZEN

L Series



Turning holder

Product No.	CTLA900055	
Ref. No.	GTF3712	CTL120155
Speed ratio	-	
RPM Max.	-	
Tool clamping	DC.T1103	



Turning holder

Product No.	CTLA900035	
Ref. No.	-	CTL120135
Speed ratio	-	
RPM Max.	-	
Tool clamping	VC.T1103	



Turning holder

Product No.	CTLA900060	
Ref. No.	-	CTL120160
Speed ratio	-	
RPM Max.	-	
Tool clamping	TGF32R 175 PR930	



Turning holder

Product No.	CTLA910101	
Ref. No.	-	CTL12100100
Speed ratio	-	
RPM Max.	-	
Tool clamping	□10	



Turning holder

Product No.	CTLA912301	
Ref. No.	-	CTL2012100
Speed ratio	-	
RPM Max.	-	
Tool clamping	□12	



Turning holder

Product No.	CTLA912201	
Ref. No.	GTF6312	CTL2212100
Speed ratio	-	
RPM Max.	-	
Tool clamping	□12	



Turning holder for sub spindle

Product No.	CTLB912301	
Ref. No.	-	CTL620100-1
Speed ratio	-	
RPM Max.	-	
Tool clamping	□12	



Turning holder for sub spindle

Product No.	CTLBA25000+COMBADL550	
Ref. No.	-	CTL620100
Speed ratio	-	
RPM Max.	-	
Tool clamping	DC.T11T3	



Boring bar holder for sub spindle

Product No.	CTLBA25000+COMBAB0000	
Ref. No.	-	CTL601200
Speed ratio	-	
RPM Max.	-	
Tool clamping	Ø3/4/5/6/8/9/10/12/16	

CITIZEN

A Series



Drill holder (deep hole)

Product No.	CTAA802201	
Ref. No.	—	CTA162000
Speed ratio	—	
RPM Max.	—	
Tool clamping	ER16M	



3-spindle double drilling/milling unit

Product No.	CTAA2B3301	
Ref. No.	GSE1710	CTA546300
Speed ratio	1:1	
RPM Max.	4000	
Tool clamping	ER16AM	



Double drilling/milling unit

Product No.	CTAA2B1201	
Ref. No.	BSE107	CTA511000
Speed ratio	1:1	
RPM Max.	4000	
Tool clamping	ER11M	



※Option: cutter

Polygon unit

Product No.	CTAA400201	
Ref. No.	—	CTA150100-1
Speed ratio	1:1	
RPM Max.	5000	
Tool clamping	—	



Boring bar holder

Product No.	CTAA803201	
Ref. No.	—	CTA140300
Speed ratio	—	
RPM Max.	—	
Tool clamping	Ø20	



Boring bar holder

Product No.	CTAA803202	
Ref. No.	—	CTA140300-1
Speed ratio	—	
RPM Max.	—	
Tool clamping	Ø19.05	

MIYANO

BND, BNE, BNJ, ABX

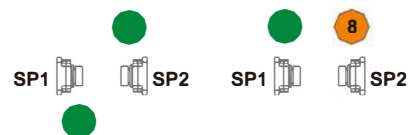

Axial drilling/milling unit

Product No.	BM45MI1A0101
Ref. No.	2W785600 BMT4510102005500
Speed ratio	1:1
RPM Max.	6000
Tool clamping	ER20A



Axial drilling/milling unit

Product No.	BM45MI1A0202
Ref. No.	— BMT4550101605500
Speed ratio	1:1
RPM Max.	6000
Tool clamping	ER16A



Radial drilling/milling unit 25bar

Product No.	BM45MI1B0101
Ref. No.	2W785550 BMT4520112005500
Speed ratio	1:1
RPM Max.	6000
Tool clamping	ER20A



Axial drilling/milling unit

Product No.	BM38MI1A0103
Ref. No.	DV70B001 BMT3810111610900
Speed ratio	1:1
RPM Max.	6000
Tool clamping	ER16A



Radial drilling/milling unit

Product No.	BM38MI1B0104
Ref. No.	DV70A000 BMT3820111610900
Speed ratio	1:1
RPM Max.	6000
Tool clamping	ER16A



Axial drilling/milling unit

Product No.	BM45MI1A0102
Ref. No.	2K700000 BMT4510302011600
Speed ratio	1:1
RPM Max.	6000
Tool clamping	ER20A



Radial drilling/milling unit 25bar

Product No.	BM45MI1B0102
Ref. No.	2K701000 BMT4520312011600
Speed ratio	1:1
RPM Max.	4000
Tool clamping	ER20A

MIYANO

BND, BNE, BNJ, ABX



Turning holder

Product No.	BM45MI2A2001	
Ref. No.	1X780100	MYB020100
Speed ratio	-	
RPM Max.	-	
Tool clamping	□20	



Turning holder

Product No.	BM45MI2A2005	
Ref. No.	1X780200	MYE900100
Speed ratio	-	
RPM Max.	-	
Tool clamping	□20	



Turning holder

Product No.	BM45MI2B2002	
Ref. No.	1X784100	MYD902000
Speed ratio	-	
RPM Max.	-	
Tool clamping	□20	



Turning holder

Product No.	BM45MI2B2001	
Ref. No.	1X784600	MYB020200
Speed ratio	-	
RPM Max.	-	
Tool clamping	□20	



Multiple holder

Product No.	BM45MI2E0001	
Ref. No.	1X780500	MYJ920100
Speed ratio	-	
RPM Max.	-	
Tool clamping	□20 Ø25	



Boring bar holder

Product No.	BM45MI2D2501	
Ref. No.	1X780600	MYE040200
Speed ratio	-	
RPM Max.	-	
Tool clamping	Ø25	



Turning holder

Product No.	BM38MI2A2006	
Ref. No.		MYJ920100-1
Speed ratio	-	
RPM Max.	-	
Tool clamping	□20	



Boring bar holder

Product No.	BM38MI2D1501	
Ref. No.	2K749001	MYJ940100
Speed ratio	-	
RPM Max.	-	
Tool clamping	Ø25	



Boring bar holder

Product No.	BM38MI2D2503	
Ref. No.	DV73B000	MYLB35BC32A00
Speed ratio	-	
RPM Max.	-	
Tool clamping	Ø25	

MIYANO

BNA



Axial drilling/milling unit

Product No.	BM38MI1A010
Ref. No.	CG70A000 BMT3810101603700
Speed ratio	1:1
RPM Max.	8000
Tool clamping	ER16A



Axial drilling/milling unit

Product No.	BM38MI1A0201
Ref. No.	CL70A000 BMT385010112200
Speed ratio	1:1.66
RPM Max.	6000
Tool clamping	ER11A



Radial drilling/milling unit 25bar

Product No.	BM38MI1B0102
Ref. No.	CG70C000 BMT3820111603700
Speed ratio	1:1
RPM Max.	6000
Tool clamping	ER16A



Radial drilling/milling unit

Product No.	BM38MI1B0101
Ref. No.	CG70D000 BMT3820101602200
Speed ratio	1:1
RPM Max.	6000
Tool clamping	ER16A



Radial drilling/milling unit

Product No.	BM38MI1B0202
Ref. No.	— BMT384010162200-1
Speed ratio	1:1
RPM Max.	6000
Tool clamping	ER11



Radial drilling/milling unit

Product No.	BM38MI1B0201
Ref. No.	CG70E000 BMT384010162200
Speed ratio	1:1
RPM Max.	6000
Tool clamping	ER16A



Turning holder (cut-off)

Product No.	BM38MI2A2001
Ref. No.	CG73C000 MYA10201GC00
Speed ratio	—
RPM Max.	—
Tool clamping	□20



Turning holder

Product No.	BM38MI2A2003
Ref. No.	CG73M000 MYA10201GM00
Speed ratio	—
RPM Max.	—
Tool clamping	□20

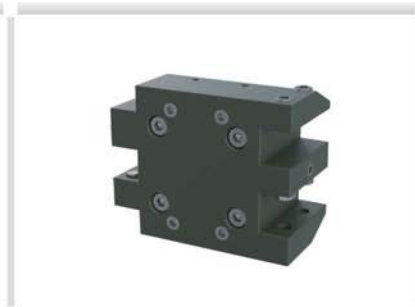

Turning holder

Product No.	BM38MI2B2001
Ref. No.	CL73A001 MYA10203LA00
Speed ratio	—
RPM Max.	—
Tool clamping	□20

MIYANO

BNA



Turning holder

Product No.	BM38MI2B2002	
Ref. No.	CG73L000	MYA10202GL00
Speed ratio	-	
RPM Max.	-	
Tool clamping	□20	



Boring bar holder

Product No.	BM38MI2D2501	
Ref. No.	CG73P000	MYA20252GP00
Speed ratio	-	
RPM Max.	-	
Tool clamping	Ø25	



Boring bar holder

Product No.	BM38MI2D3501	
Ref. No.	CG73E000	MYA20253GE00
Speed ratio	-	
RPM Max.	-	
Tool clamping	Ø25	



Boring bar holder

Product No.	BM38MI2D4501	
Ref. No.	CL73B000	MYA20254LB00
Speed ratio	-	
RPM Max.	-	
Tool clamping	Ø25	

MIYANO

BNC



Turning holder

Product No.	BM38MI2A2005	
Ref. No.	7S780100	MYC900100-R
Speed ratio	-	
RPM Max.	-	
Tool clamping	□20	



Turning holder

Product No.	BM38MI2A2004	
Ref. No.	7S780200	MYC900100
Speed ratio	-	
RPM Max.	-	
Tool clamping	□20	



Axial drilling/milling unit

Product No.	BM38MI1A0102	
Ref. No.	1U783000	BMT3810301605100
Speed ratio	1:1	
RPM Max.	6000	
Tool clamping	ER16A	

GANESH

CB Series



Gear hobbing unit

Product No.	CCBA610301
Ref. No.	— CCB130100
Speed ratio	1:1
RPM Max.	6000
Tool clamping	Ø10xØ30x20



Cross drilling/milling unit, 2-spindle

Product No.	CCBA116301
Ref. No.	— CCB162000
Speed ratio	1:1
RPM Max.	6000
Tool clamping	ER16A

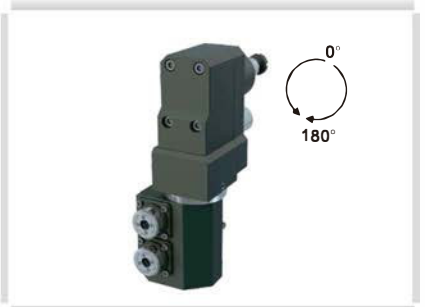

2-spindle drilling/milling unit ⚙️

Product No.	CCBA2A2301
Ref. No.	— CCB491200
Speed ratio	1:1
RPM Max.	6000
Tool clamping	ER11



4-spindle double drilling/milling unit

Product No.	CCBA2B4301
Ref. No.	— CCB562400
Speed ratio	1:2 ⬆️
RPM Max.	6000
Tool clamping	ER20M*4/ER16M*4+Ø25*5



5-spindle double drilling/milling unit

Product No.	CCBA2B5301
Ref. No.	— CCB566500
Speed ratio	1:2 ⬆️
RPM Max.	6000
Tool clamping	ER16A*5/ER11A*5+Ø25*5



5-spindle double drilling/milling unit

Product No.	CCBA2B5302
Ref. No.	— CCB566500-1
Speed ratio	1:1
RPM Max.	6000
Tool clamping	ER16A*5/ER11A*5+Ø25*5



Slotting unit for sub spindle

Product No.	CCBB700301
Ref. No.	— CCB730000
Speed ratio	1:0.75 ⬇️
RPM Max.	3000
Tool clamping	Ø6/12.7xØ45



Cross drilling/milling unit for sub spindle

Product No.	CCBB316301
Ref. No.	— CCB761000
Speed ratio	1:1
RPM Max.	5000
Tool clamping	ER16



3-spindle drilling/milling unit ⚙️

Product No.	CCYA2A3501
Ref. No.	— CCY463000
Speed ratio	1:1
RPM Max.	5000
Tool clamping	ER16M

GANESH

CB



Turning holder for sub spindle

Product No.	CCBB912302
Ref. No.	— CCB611120
Speed ratio	—
RPM Max.	—
Tool clamping	□12



Turning holder for sub spindle

Product No.	CCBB912301
Ref. No.	— CCB62014200-12
Speed ratio	—
RPM Max.	—
Tool clamping	□12



Turning holder for sub spindle

Product No.	CCBB916301
Ref. No.	— CCB62014200-16
Speed ratio	—
RPM Max.	—
Tool clamping	□16



Drill holder for sub spindle

Product No.	CCBB81Q302
Ref. No.	— CCB64014200-20
Speed ratio	—
RPM Max.	—
Tool clamping	ER20A



Boring bar holder for sub spindle

Product No.	CCBB82Q302
Ref. No.	— CCB601120
Speed ratio	—
RPM Max.	—
Tool clamping	Ø12



Drill holder for sub spindle

Product No.	CCBB82Q301
Ref. No.	— CCB640300
Speed ratio	—
RPM Max.	—
Tool clamping	Ø25

GANESH

CT-52YM



Axial drilling/milling unit

Product No.	BM65NK1A0101
Ref. No.	– BMT6510103209200
Speed ratio	1:1
RPM Max.	6000
Tool clamping	ER32UM



Axial drilling/milling unit  30bar

Product No.	BM65NK1A0102
Ref. No.	– BMT6510113209200
Speed ratio	1:1
RPM Max.	6000
Tool clamping	ER32UM



Gear hobbing unit 

Product No.	BM65NK1F2221
Ref. No.	– BMT6507221100
Speed ratio	2:1 
RPM Max.	3000
Tool clamping	Ø22.225xØ80x80



Radial drilling/milling unit

Product No.	BM65NK1B0101
Ref. No.	– BMT6520103209200
Speed ratio	1:1
RPM Max.	6000
Tool clamping	ER32UM



Radial drilling/milling unit  30bar

Product No.	BM65NK1B0102
Ref. No.	– BMT6520113209200
Speed ratio	1:1
RPM Max.	6000
Tool clamping	ER32UM



Universal drilling/milling unit 

Product No.	BM65NK1H1801
Ref. No.	– BMT6532102009200
Speed ratio	1:1
RPM Max.	6000
Tool clamping	ER20

NOMURA

YB Series



Tool holder

Product No.	NUYA0001	
Ref. No.	–	NUT160500
Speed ratio	–	
RPM Max.	–	
Tool clamping	–	



Cross drilling/milling unit

Product No.	NUYA120201	
Ref. No.	–	NUY262100
Speed ratio	1:1	
RPM Max.	6000	
Tool clamping	ER20M	



2-spindle drilling/milling unit

Product No.	NUYA2A2301	
Ref. No.	–	NUN446200
Speed ratio	1:1	
RPM Max.	6000	
Tool clamping	ER16M	

SB Series



4-spindle drilling/milling unit

Product No.	NUSA2A4101	
Ref. No.	–	NUB261300-1
Speed ratio	1:1	
RPM Max.	6000	
Tool clamping	ER11	



Cross drilling/milling unit, 3-spindle

Product No.	NUSA111102	
Ref. No.	–	NUB261300
Speed ratio	1:1	
RPM Max.	6000	
Tool clamping	ER11M	



2-spindle drilling/milling unit

Product No.	NUSA2A2102	
Ref. No.	–	NUB441200
Speed ratio	1:1	
RPM Max.	6000	
Tool clamping	ER11	



Cross drilling/milling unit, 2-spindle

Product No.	NUSA116101	
Ref. No.	–	NUB266200
Speed ratio	1.59:1 ↓	
RPM Max.	6000	
Tool clamping	ER16M	



Cross drilling/milling unit, 3-spindle

Product No.	NUSA116102	
Ref. No.	–	NUB266300
Speed ratio	1:1	
RPM Max.	6000	
Tool clamping	ER16M	

NOMURA

UB Series



Cross drilling/milling unit



Cross drilling/milling unit



Idler shaft

Product No.	NUUA116204	NUUA116201	NUUA100000
Ref. No.	—	—	—
	NUB246100	NUU266100	NUB200000
Speed ratio	1:1	1:1	—
RPM Max.	6000	6000	—
Tool clamping	ER16M	ER16M	—



3-spindle drilling/milling unit



Non-guide bush device

Product No.	NUUA2A3202	NUU25500
Ref. No.	—	—
	NUN441300	NUU25500
Speed ratio	1:1	—
RPM Max.	6000	—
Tool clamping	ER11M	—

NOMURA

Other



3-spindle drilling/milling unit



Cross drilling/milling unit 

Product No.	NUJA2A3201	NUBA108201
Ref. No.	—	—
	NUJ441300	NUB248100
Speed ratio	1:1	1:1
RPM Max.	6000	6000
Tool clamping	ER11A	ER8M

Price

NOMURA

Back Processing Static Tool Holder Shaft: Ø22, Ø23



Drill holder for sub spindle

Product No.	NUUB81Q201 / NUUB81Q203
Ref. No.	– NUAB22HBA00
Speed ratio	– NUAB22HCA00
RPM Max.	–
Tool clamping	ER16M



Drill holder for sub spindle

Product No.	NUYB81Q301 / NUYB81Q302
Ref. No.	– NUDA22HBA00
Speed ratio	– NUDA22HCA00
RPM Max.	–
Tool clamping	ER16M



Drill holder for sub spindle (deep hole)

Product No.	NUYB81Q304 / NUYB81Q303
Ref. No.	– NUDA22HBB00
Speed ratio	– NUDA22HCB00
RPM Max.	–
Tool clamping	ER16M



Turning holder for sub spindle

Product No.	NUUB910201 / NUUB910202
Ref. No.	– NUN620100-2
Speed ratio	– NUN620100-3
RPM Max.	–
Tool clamping	□10

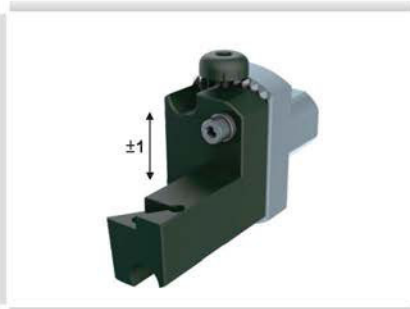

Turning holder for sub spindle

Product No.	NUUBA22000+COMBADL550
Ref. No.	– NUN620100-1
Speed ratio	–
RPM Max.	–
Tool clamping	DC..11T3



Turning holder for sub spindle

Product No.	NUUBA22000+COMBADR550
Ref. No.	– NUN620100-6
Speed ratio	–
RPM Max.	–
Tool clamping	DC.11T3



Turning holder for sub spindle

Product No.	NUUBA22000+COMBAC1000
Ref. No.	– NUN620100
Speed ratio	–
RPM Max.	–
Tool clamping	□10



Reamer tool holder

Product No.	NUUA0002 / NUUA0003
Ref. No.	– GPN112200
Speed ratio	– GPN112300
RPM Max.	–
Tool clamping	ER11M

NOMURA

Symbology

Internal Coolant/BAR Speeder Reducer Adjustable

HANWHA

XD20H



Cross drilling/milling unit

Product No.	HWDA116201
Ref. No.	– HWX246100
Speed ratio	1:1
RPM Max.	8000
Tool clamping	ER16A



3-spindle drilling/milling unit

Product No.	HWDA2A3201
Ref. No.	– HWX446300
Speed ratio	1:1
RPM Max.	6000
Tool clamping	ER16M



3-spindle double drilling/milling unit

Product No.	HWDA2B3202
Ref. No.	– HWX546300
Speed ratio	1:1
RPM Max.	6000
Tool clamping	ER16M/ER11M



2-spindle drilling/milling unit ⚙️

Product No.	HWDA2A2203
Ref. No.	– HWX491200
Speed ratio	1:1
RPM Max.	8000
Tool clamping	ER11M



3-spindle drilling/milling unit ⚙️

Product No.	HWDA2A3202
Ref. No.	– HWX496300
Speed ratio	1:1
RPM Max.	8000
Tool clamping	ER16M



3-spindle double drilling/milling unit ⚙️

Product No.	HWDA2B3204
Ref. No.	– HWX596300
Speed ratio	1:1
RPM Max.	8000
Tool clamping	ER16M/ER11M



Thread whirling unit ⚙️

Product No.	HWDA545205
Ref. No.	– HWX260100
Speed ratio	1:1
RPM Max.	6000
Tool clamping	Utilis no.119287



Boring bar holder

Product No.	HWDA803201
Ref. No.	– HWX140300
Speed ratio	–
RPM Max.	–
Tool clamping	Ø25



Boring bar holder

Product No.	HWDA803202
Ref. No.	– HWX140300-1
Speed ratio	–
RPM Max.	–
Tool clamping	Ø25

HANWHA

XD20H



Drilling/milling unit for sub spindle

Product No.	HWDB116201	
Ref. No.	—	HWX746100
Speed ratio	1:1	
RPM Max.	8000	
Tool clamping	ER16A	



Cross drilling/milling unit for sub spindle

Product No.	HWDB311201	
Ref. No.	—	HWX731100-1
Speed ratio	1:0.55	
RPM Max.	4000	
Tool clamping	ER11A	



Cross drilling/milling unit for sub spindle

Product No.	HWDB311202	
Ref. No.	—	
Speed ratio	1:1	
RPM Max.	4000	
Tool clamping	ER11A	



Cross drilling/milling unit for sub spindle

Product No.	HWDB316202	
Ref. No.	—	HWX736100-1
Speed ratio	1:0.55	
RPM Max.	4000	
Tool clamping	ER16A	



Slotting unit for sub spindle

Product No.	HWDB700201	
Ref. No.	—	HWX730100
Speed ratio	1:0.55	
RPM Max.	4000	
Tool clamping	Ø5/6/8/10/12.7/13xØ50	

HANWHA

XD20HII



Cross drilling/milling unit

Product No.	HWDA116202	
Ref. No.	—	HWX246100-1
Speed ratio	1:1	
RPM Max.	6000	
Tool clamping	ER16A	

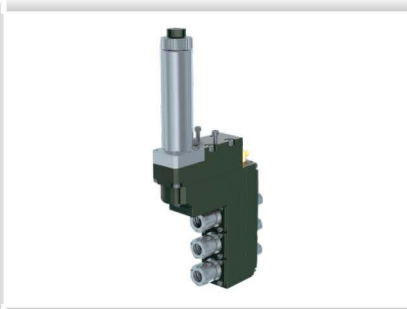

3-spindle double drilling/milling unit

Product No.	HWDA2B3207	
Ref. No.	—	HWX546300-2
Speed ratio	1:1	
RPM Max.	6000	
Tool clamping	ER16M/ER11M	

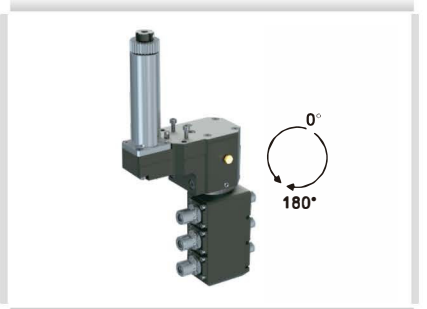

3-spindle double drilling/milling unit

Product No.	HWDA2B3208	
Ref. No.	—	HWX591300-2
Speed ratio	1:1	
RPM Max.	8000	
Tool clamping	ER11M/ER8M	

HANWHA

XD32H



3-spindle drilling/milling unit

Product No.	HWDA2A3302	
Ref. No.	—	HWX446300-32
Speed ratio	1:1	
RPM Max.	6000	
Tool clamping	ER16M	



3-spindle double drilling/milling unit

Product No.	HWDA2B3302	
Ref. No.	—	HWX546300-32
Speed ratio	1:1	
RPM Max.	6000	
Tool clamping	ER16M/ER11M	



3-spindle drilling/milling unit

Product No.	HWDA2A3301	
Ref. No.	—	HWX496300-32
Speed ratio	1:1	
RPM Max.	6000	
Tool clamping	ER16M	



Cross drilling/milling unit for sub spindle

Product No.	HWDB316301	
Ref. No.	—	HWX736100
Speed ratio	1:0.77	
RPM Max.	4000	
Tool clamping	ER16A	



Slotting unit for sub spindle

Product No.	HWDB700301	
Ref. No.	—	HWX730100-1
Speed ratio	1:0.77	
RPM Max.	4000	
Tool clamping	Ø5/6/8/10/12.7 /13xØ60	



Slotting unit for sub spindle

Product No.	HWDB700302	
Ref. No.	—	
Speed ratio	1:0.55	
RPM Max.	4000	
Tool clamping	Ø5/6/8/10/12.7 /13xØ50	

XD12H



Slotting unit for sub spindle

Product No.	HWDB700101	
Ref. No.	—	HWX731000
Speed ratio	1:0.55	
RPM Max.	4000	
Tool clamping	Ø5/6/8/10/12.7/13xØ50	



Cross drilling/milling unit for sub spindle

Product No.	HWDB311101	
Ref. No.	—	HWX731100
Speed ratio	1:0.55	
RPM Max.	4000	
Tool clamping	ER11A	



Cross drilling/milling unit for sub spindle

Product No.	HWDB316201	
Ref. No.	—	HWX866100
Speed ratio	1:1	
RPM Max.	6000	
Tool clamping	ER16M	

SWISTEK

JSL-32AB/42AB



3-spindle double drilling/milling unit

Product No.	JSSA2B3401
Ref. No.	— JSR546300-1
Speed ratio	1:1
RPM Max.	6000
Tool clamping	ER16M/ER11M



3-spindle double drilling/milling unit

Product No.	JSSA2B3402
Ref. No.	— JSR596300-1
Speed ratio	1:1
RPM Max.	6000
Tool clamping	ER16M/ER11M

JSL-42RB/RBY



Thread whirling unit

Product No.	JSSA545401
Ref. No.	— JSAA2L01000
Speed ratio	1:1
RPM Max.	6000
Tool clamping	Utilis no.119287



Slotting unit

Product No.	JSSA712401
Ref. No.	— JSR30100
Speed ratio	1:0.374
RPM Max.	4000
Tool clamping	Ø12.7xØ100



Slotting unit

Product No.	JSSA725401
Ref. No.	— JSR30100-1
Speed ratio	1:0.374
RPM Max.	4000
Tool clamping	Ø25.4xØ110



Gear hobbing unit

Product No.	JSSA616401
Ref. No.	— JSR130100
Speed ratio	1:1
RPM Max.	6000
Tool clamping	Ø16xØ40x42



Drilling/milling unit for sub spindle

Product No.	JSSB120401
Ref. No.	— JSR762100
Speed ratio	1:1
RPM Max.	8000
Tool clamping	ER20M



Cross drilling/milling unit for sub spindle

Product No.	JSSB316401
Ref. No.	— JSR730100
Speed ratio	1:1
RPM Max.	4000
Tool clamping	ER16A



Cross drilling/milling unit for sub spindle

Product No.	JSSB316403
Ref. No.	— JSR866100-1
Speed ratio	1:1
RPM Max.	6000
Tool clamping	ER16M



Cross drilling/milling unit for sub spindle

Product No.	JSSB316402
Ref. No.	— JSR866100
Speed ratio	1:1
RPM Max.	6000
Tool clamping	ER16M

SWISTEK

RB, SV, SW

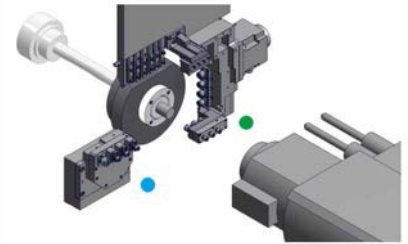

SWISTEK

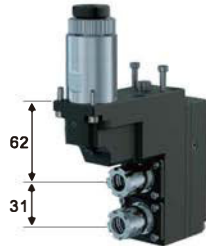

2-spindle drilling/milling unit

Product No.	STRA2A2204
Ref. No.	54151 STR446200
Speed ratio	1:1
RPM Max.	6000
Tool clamping	ER16M

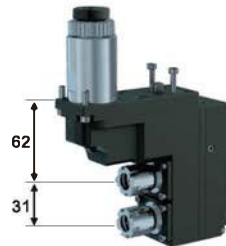

2-spindle double drilling/milling unit

Product No.	STRA2B2202
Ref. No.	66159 STR546200
Speed ratio	1:1
RPM Max.	6000
Tool clamping	ER16M/ER11M

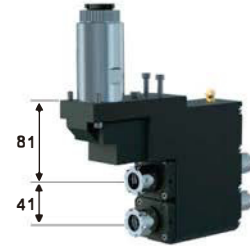

2-spindle double drilling/milling unit

Product No.	STRA2B2302
Ref. No.	10169 STJA5N22000
Speed ratio	1:1
RPM Max.	5000
Tool clamping	ER20M/ER16M

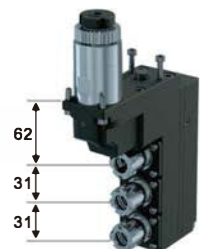

3-spindle drilling/milling unit

Product No.	STRA2A3201
Ref. No.	66151 STR446300
Speed ratio	1:1
RPM Max.	6000
Tool clamping	ER16M

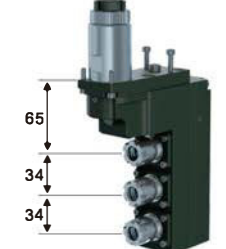

3-spindle drilling/milling unit

Product No.	STRA2A3301
Ref. No.	67151 STR446300-1
Speed ratio	1:1
RPM Max.	6000
Tool clamping	ER16M

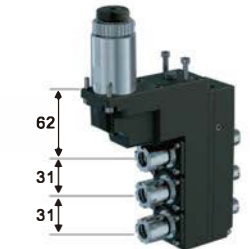

3-spindle double drilling/milling unit

Product No.	STRA2B3201
Ref. No.	67161 STR546300
Speed ratio	1:1
RPM Max.	6000
Tool clamping	ER16M/ER11M



3-spindle double drilling/milling unit

Product No.	STRA2B3301
Ref. No.	67159 STR546300-1
Speed ratio	1:1
RPM Max.	6000
Tool clamping	ER16M/ER11M



3-spindle drilling/milling unit ⚡

Product No.	STRA2A3202
Ref. No.	— STR496300
Speed ratio	1:1
RPM Max.	6000
Tool clamping	ER16M

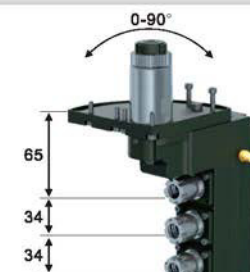

3-spindle drilling/milling unit ⚡

Product No.	STRA2A3302
Ref. No.	— STR496300-1
Speed ratio	1:1
RPM Max.	6000
Tool clamping	ER16M

SWISTEK

RB, SV, SW

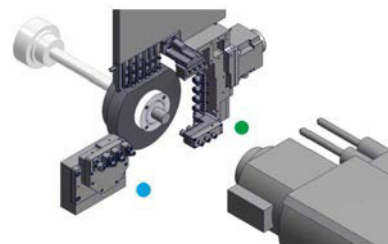

SWISTEK



2-spindle drilling/milling unit ⚙️

Product No.	STRA2A2202
Ref. No.	— STR496200
Speed ratio	1:1
RPM Max.	6000
Tool clamping	ER16M

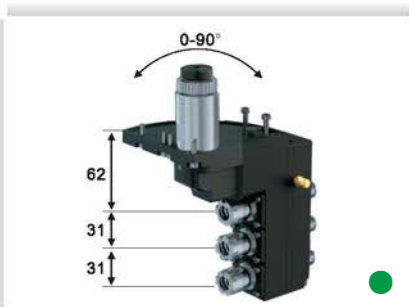

3-spindle double drilling/milling unit ⚙️

Product No.	STRA2B3202
Ref. No.	— STR596300
Speed ratio	1:1
RPM Max.	6000
Tool clamping	ER16M/ER11M

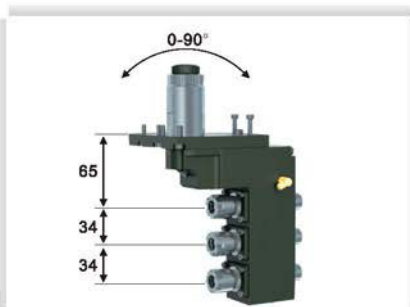

3-spindle double drilling/milling unit ⚙️

Product No.	STRA2B3302
Ref. No.	— STR596300-1
Speed ratio	1:1
RPM Max.	6000
Tool clamping	ER16M/ER11M

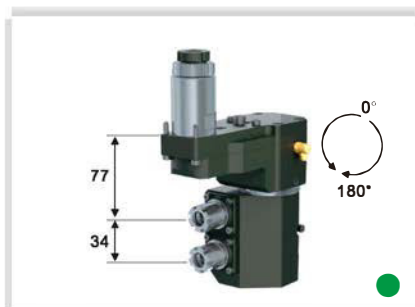

2-spindle drilling/milling unit ⚙️

Product No.	STRA2A2303
Ref. No.	— STR496200-2
Speed ratio	1:1
RPM Max.	6000
Tool clamping	ER16M

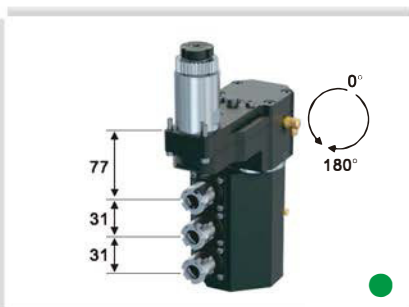

3-spindle drilling/milling unit ⚙️

Product No.	STRA2A3203
Ref. No.	— STR496300-2
Speed ratio	1:1
RPM Max.	6000
Tool clamping	ER16M

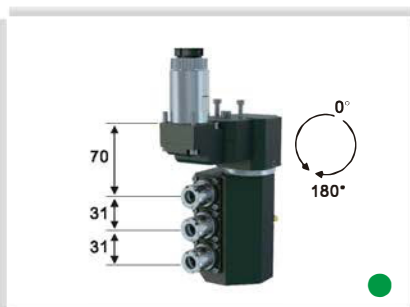

3-spindle drilling/milling unit ⚙️

Product No.	STRA2A3207
Ref. No.	— STR496300-5
Speed ratio	1:1
RPM Max.	6000
Tool clamping	ER16M



Cross drilling/milling unit

Product No.	STRA116202 / STRA120201
Ref. No.	33150 STR161000
Speed ratio	1:1
RPM Max.	8000
Tool clamping	ER16M / ER20M



Cross drilling/milling unit

Product No.	STRA116201
Ref. No.	57155 STR166100
Speed ratio	1:1
RPM Max.	8000
Tool clamping	ER16M



Cross drilling/milling unit

Product No.	STRA111202
Ref. No.	— STR161100
Speed ratio	1:3 ⬆️
RPM Max.	18000
Tool clamping	ER11A

SWISTEK

RB, SV, SW

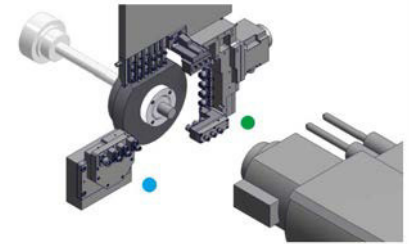

SWISTEK



Cross drilling/milling unit, 3-spindle

Product No.	STRA111201
Ref. No.	— STR261300
Speed ratio	1:1
RPM Max.	8000
Tool clamping	ER11M



Slotting unit

Product No.	STRA712201
Ref. No.	54153 STR301000
Speed ratio	1:0.374 ↓
RPM Max.	4000
Tool clamping	Ø12.7xØ50



Thread whirling unit ⬆

Product No.	STRA545203
Ref. No.	68172 STR260100N
Speed ratio	1:1
RPM Max.	6000
Tool clamping	Utilis no.119287



※Option: cutter

Polygon unit

Product No.	STRA400201
Ref. No.	54191 STR150100
Speed ratio	1:1
RPM Max.	3000
Tool clamping	—



Gear hobbing unit ⬆

Product No.	STRA613201
Ref. No.	— STR130100
Speed ratio	1:1
RPM Max.	6000
Tool clamping	Ø13xØ30x20



Idler shaft

Product No.	STRA100000
Ref. No.	57189 STR160000
Speed ratio	—
RPM Max.	—
Tool clamping	—



Boring bar holder

Product No.	STRA803307
Ref. No.	— STR14036200
Speed ratio	—
RPM Max.	—
Tool clamping	Ø22



Air tool holder ⬆

Product No.	STRA0002
Ref. No.	— STR210300
Speed ratio	—
RPM Max.	—
Tool clamping	Ø22



Air tool holder

Product No.	STBA0004
Ref. No.	— STB410100
Speed ratio	—
RPM Max.	—
Tool clamping	Ø22



SWISTEK

RB, SV, SW

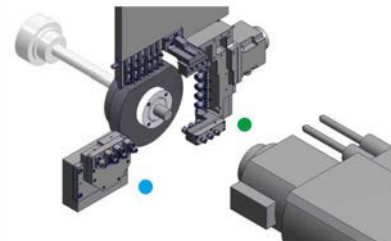

SWISTEK



Air tool holder for sub spindle

Product No.	STRB0001
Ref. No.	— STR14036200
Speed ratio	—
RPM Max.	—
Tool clamping	Ø22.8



Slotting unit for sub spindle ⚙️

Product No.	STRB700201
Ref. No.	69166/69165 STR731000
Speed ratio	1:0.55 ↓
RPM Max.	4000
Tool clamping	Ø5/6/8/10/12.7/13xØ50



Slotting unit for sub spindle ⚙️

Product No.	STRB700202
Ref. No.	0R165 STR731000-1
Speed ratio	1:0.55 ↓
RPM Max.	4000
Tool clamping	Ø5/6/8/10/12.7/13xØ50



Drilling/milling unit for sub spindle

Product No.	STRB111208
Ref. No.	54161 STR711000
Speed ratio	1:1
RPM Max.	6000
Tool clamping	ER11M



Drilling/milling unit for sub spindle

Product No.	STRB116202
Ref. No.	57161 STR761000
Speed ratio	1:1
RPM Max.	6000
Tool clamping	ER16M



Drilling/milling unit for sub spindle

Product No.	STRB111204
Ref. No.	— STR761200
Speed ratio	1:3 ↑
RPM Max.	18000
Tool clamping	ER11



Drilling/milling unit for sub spindle, 3-spindle

Product No.	STRB108101
Ref. No.	— STR748400
Speed ratio	1:1
RPM Max.	8000
Tool clamping	ER8M



Drilling/milling unit for sub spindle, 3-spindle

Product No.	STRB111201
Ref. No.	0E151 STR741300
Speed ratio	1:1
RPM Max.	8000
Tool clamping	ER11M



SWISTEK

RB, SV, SW

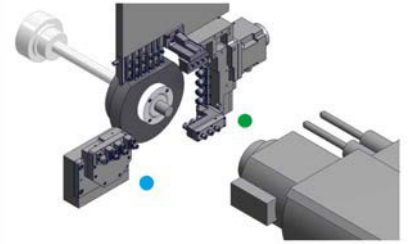

SWISTEK



Cross drilling/milling unit for sub spindle

Product No.	STRB311201
Ref. No.	— STR731100
Speed ratio	1:0.55
RPM Max.	4000
Tool clamping	ER11A



Cross drilling/milling unit for sub spindle

Product No.	STRB316202
Ref. No.	— STR736100
Speed ratio	1:0.77
RPM Max.	4000
Tool clamping	ER16A



Cross drilling/milling unit for sub spindle

Product No.	STRB316201
Ref. No.	OR151 STR861100-1
Speed ratio	1:1
RPM Max.	6000
Tool clamping	ER16M



Cross drilling/milling unit for sub spindle

Product No.	STRB311101
Ref. No.	— STR861100-3
Speed ratio	1:1
RPM Max.	6000
Tool clamping	ER11



Cross drilling/milling unit for sub spindle

Product No.	STRB311204
Ref. No.	— STR861100-2
Speed ratio	1:1
RPM Max.	6000
Tool clamping	ER11



Cross drilling/milling unit for sub spindle

Product No.	STRB311301
Ref. No.	— STR861100-5
Speed ratio	1:1
RPM Max.	6000
Tool clamping	ER11



Cross drilling/milling unit for sub spindle

Product No.	STRB311203
Ref. No.	0E152 STR861100
Speed ratio	1:1
RPM Max.	8000
Tool clamping	ER11M



Cross drilling/milling unit for sub spindle

Product No.	STRB311202
Ref. No.	— STR861100-4
Speed ratio	1:1
RPM Max.	6000
Tool clamping	ER11



Drilling/milling unit for sub spindle

Product No.	STRB111203
Ref. No.	— STR741300-1
Speed ratio	1:1
RPM Max.	8000
Tool clamping	ER11



SWISTEK

RB, SV, SW

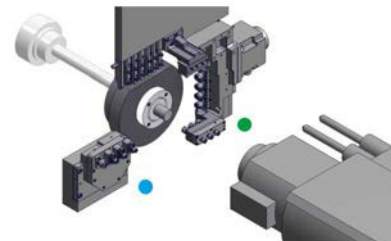

Drill holder for sub spindle

Product No.	STRB81Q309
Ref. No.	— STR646100-1
Speed ratio	—
RPM Max.	—
Tool clamping	ER16M



Drill holder for sub spindle

Product No.	STRB81Q307
Ref. No.	54121 STR646100-5
Speed ratio	—
RPM Max.	—
Tool clamping	ER16M



Drill holder for sub spindle 25bar

Product No.	STRB81Q304
Ref. No.	— STR646100-2
Speed ratio	—
RPM Max.	—
Tool clamping	ER16M



Drill holder for sub spindle

Product No.	STRB81Q305
Ref. No.	— STR642100
Speed ratio	—
RPM Max.	—
Tool clamping	ER20M



Drill holder for sub spindle

Product No.	STRB81Q313
Ref. No.	67122 STR642100-3
Speed ratio	—
RPM Max.	—
Tool clamping	ER20M



Drill holder for sub spindle 25bar

Product No.	STRB81Q303
Ref. No.	— STR642100-1
Speed ratio	—
RPM Max.	—
Tool clamping	ER20M

SWISTEK

SWISTEK

RB, SV, SW

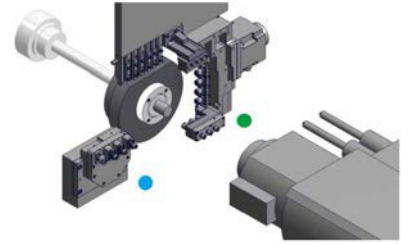

SWISTEK



Drill holder for sub spindle

Product No.	STRB81Q101	
Ref. No.	69125	STR64110010J
Speed ratio	-	
RPM Max.	-	
Tool clamping	ER11M	



Drill holder for sub spindle

Product No.	STRB81Q201	
Ref. No.	-	STR64110020R
Speed ratio	-	
RPM Max.	-	
Tool clamping	ER11M	



※ER drill holder not included

Drill holder for sub spindle

Product No.	STRB82Q201	
Ref. No.	-	STJ640100
Speed ratio	-	
RPM Max.	-	
Tool clamping	Ø16	



※ER drill holder not included

Drill holder for sub spindle

Product No.	STRB82Q202	
Ref. No.	-	STJ640200
Speed ratio	-	
RPM Max.	-	
Tool clamping	Ø16	



Boring bar holder for sub spindle

Product No.	STRB82Q200	
Ref. No.	-	STR601000
Speed ratio	-	
RPM Max.	-	
Tool clamping	Ø3/4/5/6/8/9/10/12/16	



Boring bar holder for sub spindle 

Product No.	STRBA22000+COMBAB0000	
Ref. No.	-	STR601200
Speed ratio	-	
RPM Max.	-	
Tool clamping	Ø3/4/5/6/8/9/10/12/16	



SWISTEK

RB, SV, SW

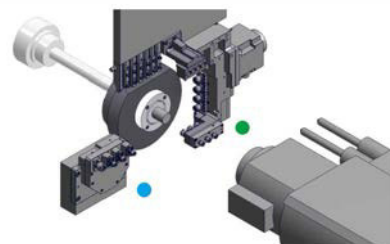

SWISTEK



Turning holder for sub spindle

Product No.	STRBA22000+COMBADL550
Ref. No.	STR620100-1
Speed ratio	—
RPM Max.	—
Tool clamping	DC.T11T3



Turning holder for sub spindle

Product No.	STRBA22000+COMBADR550
Ref. No.	STR620100-6
Speed ratio	—
RPM Max.	—
Tool clamping	DC.T11T3



Turning holder for sub spindle

Product No.	STRBA22000+COMBADL350
Ref. No.	STR620100-7
Speed ratio	—
RPM Max.	—
Tool clamping	VC.T1103



Turning holder for sub spindle

Product No.	STRB912201
Ref. No.	STR620100-3
Speed ratio	—
RPM Max.	—
Tool clamping	Ø12



Turning holder for sub spindle

Product No.	STRBA22000+COMBAC1000
Ref. No.	STR620100-2
Speed ratio	—
RPM Max.	—
Tool clamping	□10



Turning holder for sub spindle

Product No.	STRB910201
Ref. No.	STR620100
Speed ratio	—
RPM Max.	—
Tool clamping	□10



Turning holder for sub spindle

Product No.	STRB912203
Ref. No.	STR62011200
Speed ratio	—
RPM Max.	—
Tool clamping	□12



Turning holder for sub spindle

Product No.	STRB912204
Ref. No.	STR62011200-1
Speed ratio	—
RPM Max.	—
Tool clamping	□12

DOOSAN

BMT-55



Axial drilling/milling unit

Product No.	BM55DS1A0101
Ref. No.	– BMT5510102510400
Speed ratio	1:1
RPM Max.	6000
Tool clamping	ER25UM



Radial drilling/milling unit

Product No.	BM55DS1B0102
Ref. No.	– BMT5520102510400
Speed ratio	1:1
RPM Max.	6000
Tool clamping	ER25UM



Turning holder (cut-off)

Product No.	BM55DS2A2501
Ref. No.	– BMT5500A11A00
Speed ratio	–
RPM Max.	–
Tool clamping	□25



Turning holder

Product No.	BM55DS2A2503
Ref. No.	– BMT5500A21A00
Speed ratio	–
RPM Max.	–
Tool clamping	□25



Turning holder

Product No.	BM55DS2A2502
Ref. No.	– BMT5500C21A00
Speed ratio	–
RPM Max.	–
Tool clamping	□25



Boring bar holder

Product No.	BM55DS2D1501
Ref. No.	– BMT5560C41A00
Speed ratio	–
RPM Max.	–
Tool clamping	Ø25



Boring bar holder

Product No.	BM55DS2D1502
Ref. No.	– BMT5560C41B00
Speed ratio	–
RPM Max.	–
Tool clamping	Ø25

NAKAMURA

WT-150, AS-200 (BMT-55)



Axial drilling/milling unit

Radial drilling/milling unit

Turning holder (cut-off)

Product No.	BM55NK1A0101	Product No.	BM55NK1B0101	Product No.	BM55NK2A2001
Ref. No.	– BMT5510102510800	Ref. No.	– BMT5520102510800	Ref. No.	– NKAA00BB11A00
Speed ratio	1:1	Speed ratio	1:1	Speed ratio	–
RPM Max.	6000	RPM Max.	6000	RPM Max.	–
Tool clamping	ER25UM	Tool clamping	ER25UM	Tool clamping	□25

WT-100, WY-100 (BMT-44)



Turning holder

Turning holder

Boring bar holder

Boring bar holder

Product No.	BM44NK2A2001	Product No.	BM44NK2B2001	Product No.	BM44NK2D1501	Product No.	BM44NK2D2501
Ref. No.	–	Ref. No.	–	Ref. No.	–	Ref. No.	–
Speed ratio	–	Speed ratio	–	Speed ratio	–	Speed ratio	–
RPM Max.	–	RPM Max.	–	RPM Max.	–	RPM Max.	–
Tool clamping	□20	Tool clamping	□20	Tool clamping	Ø25	Tool clamping	Ø25

NEXTURN

SA20D/SA32D

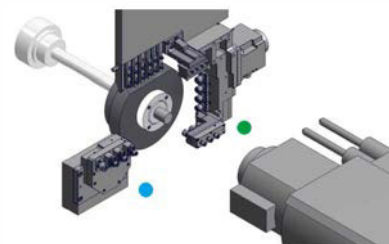

NEXTURN



Cross drilling/milling unit

Product No.	NTA246100
Ref. No.	-
Speed ratio	1:1
RPM Max.	6000
Tool clamping	ER16A

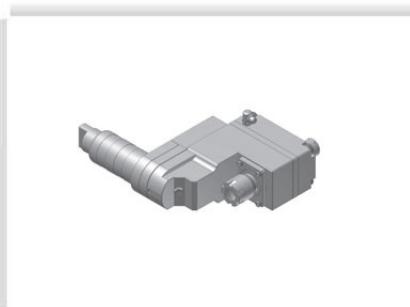

1 spindle drilling/milling unit

Product No.	NTA566100
Ref. No.	-
Speed ratio	1:1
RPM Max.	6000
Tool clamping	Front: ER16 Back: ER11M



3 spindle drilling/milling unit

Product No.	NTA566300
Ref. No.	-
Speed ratio	1:1
RPM Max.	6000
Tool clamping	Front: ER16M Back: ER11M

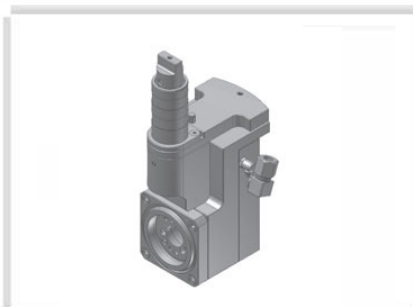

Thread Whirling Unit

Product No.	NTA260100
Ref. No.	-
Speed ratio	1:1
RPM Max.	6000
Tool clamping	-
	Thread(Max): M12
	Helix Angle: ±20°

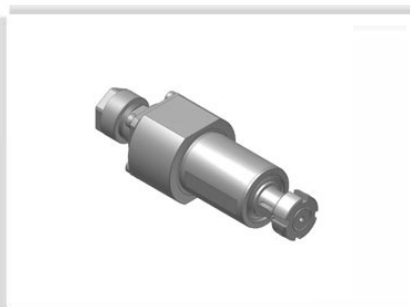

Drilling/Milling Unit (SA20D Back Post)

Product No.	NTA741100
Ref. No.	-
Speed ratio	1:1
RPM Max.	8000
Tool clamping	ER11A

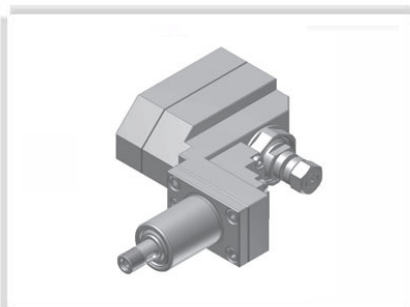

Slotting Unit (SA20D Back Post)

Product No.	NTA730100-20
Ref. No.	-
Speed ratio	1:0.55
RPM Max.	4000
Tool clamping	-
	Saw OD(Max):Ø50 mm
	Saw Arbor Shank:Ø8.0 mm



Drilling/Milling Unit (SA32D Back Post)

Product No.	NTA746100
Ref. No.	-
Speed ratio	1:1
RPM Max.	8000
Tool clamping	ER16A

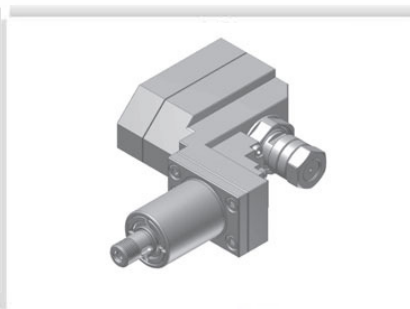

Slotting Unit (SA32D Back Post)

Product No.	NTA730100-32
Ref. No.	-
Speed ratio	1:0.55
RPM Max.	4000
Tool clamping	-
	Saw OD(Max):Ø50 mm
	Saw Arbor Shank:Ø12.0 mm 12.7 13.00