

ISO line

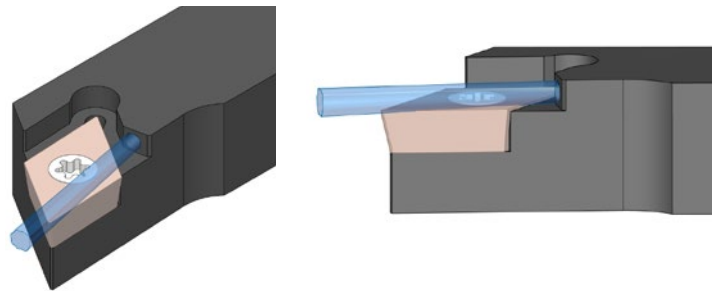

- High pressure coolant directly on the cutting edge. Coolant in the insert's axis.
- Durch Hochdruckkühlung entlang der Längsachse, direkt auf die Schneidkante der Wendepatte, erhalten Sie eine deutlich bessere Oberflächengüte und erheblich längere Standzeiten ihrer Werkzeuge.
- Arrosage haute pression sur l'arête de coupe. Jet dans l'axe de la plaquette.

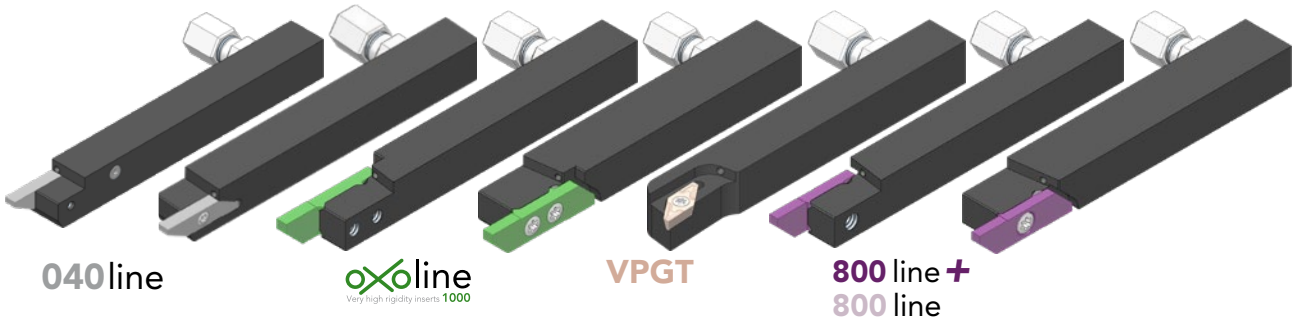
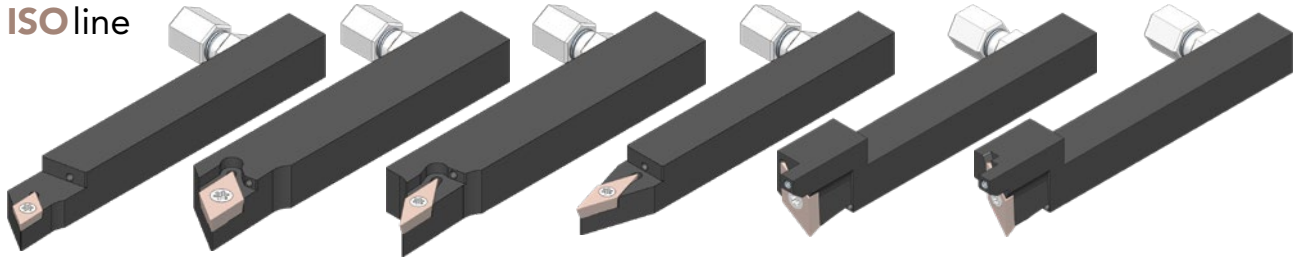
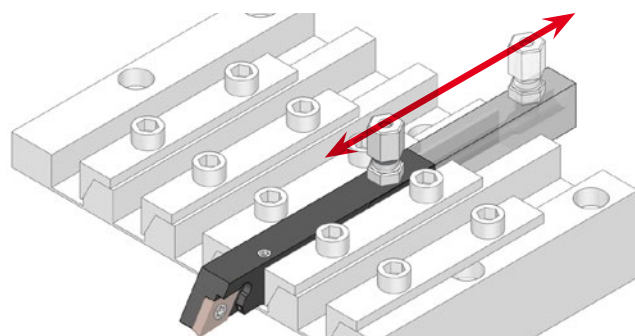

- Possibility to slide the tool holder on whole length for setting.
- Beim Einrichten können diese Werkzeughalter in ihrer gesamten Länge auf dem Träger gleiten.
- Possibilité de coulisser l'outil sur toute la longueur pour le réglage.

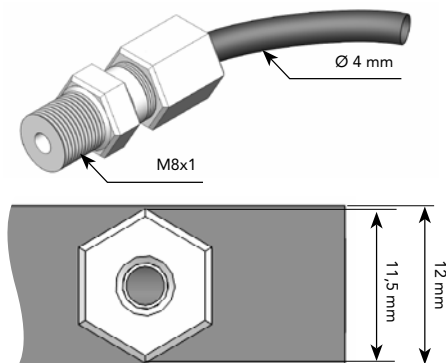

- The hydraulic fitting does not cover the tool, even for section 12x12 mm.
- Das hydraulische Anschlussstück ragt nicht über die Breite des Halters hinaus, auch nicht bei Querschnitten 12x12 mm.
- Le raccord hydraulique ne dépasse pas de l'outil même en section 12x12 mm.

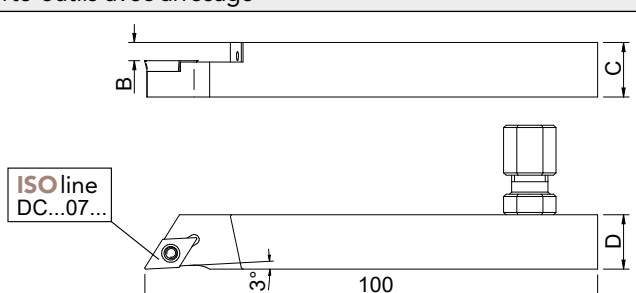
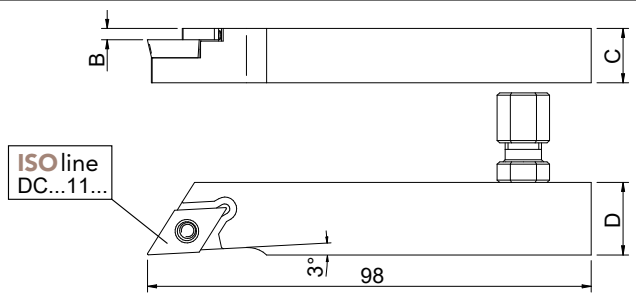
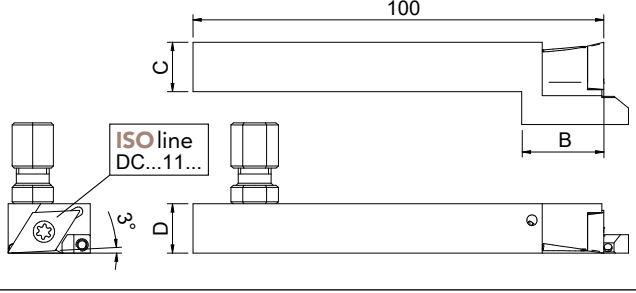
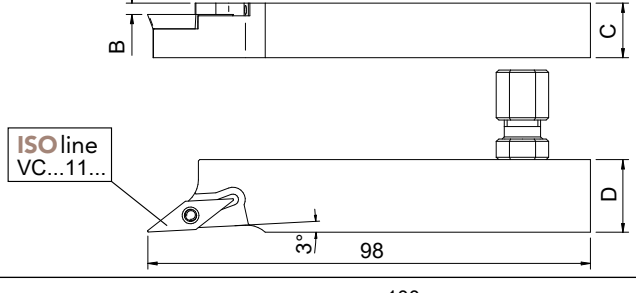
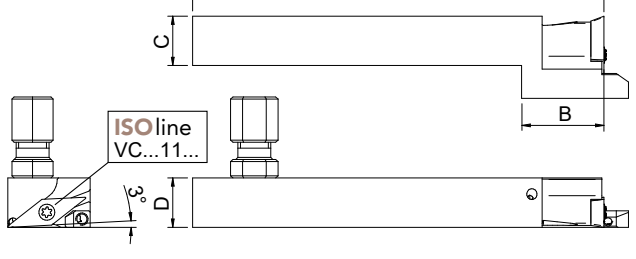
Tool holders with internal coolant Werkzeughalter mit Innenkühlung Porte-outils avec arrosage	CxD CxD CxD	B B B	Article nr. Artikel Nr. N° Article
 <p>ISO line DC...07...</p>	10x12 mm	3	SDJCR 1012 H07 IK
	12x12 mm	4	SDJCR 1212 H07 IK
	16x16 mm	4	SDJCR 1616 H07 IK
 <p>ISO line DC...11...</p>	12x15 mm	2,5	SDJCR 1215 H11 IK
	16x16 mm	2,5	SDJCR 1616 H11 IK
 <p>ISO line DC...11...</p>	12x12 mm	20	SDJCR 1212 H11 Y IK
	16x16 mm	20	SDJCR 1616 H11 Y IK
 <p>ISO line VC...11...</p>	10x15 mm	2,5	SVJCR 1015 H11 IK
	12x15 mm	2,5	SVJCR 1215 H11 IK
	16x16 mm	4	SVJCR 1616 H11 IK
 <p>ISO line VC...11...</p>	12x12 mm	20	SVJCR 1212 H11 Y IK
	16x16 mm	20	SVJCR 1616 H11 Y IK

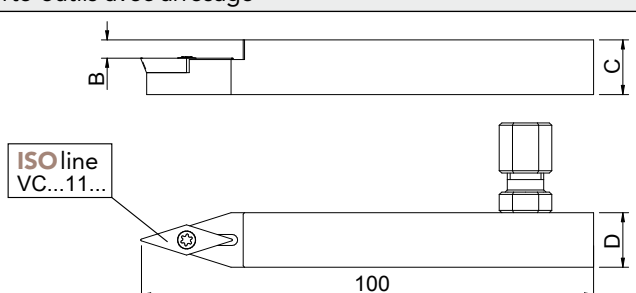
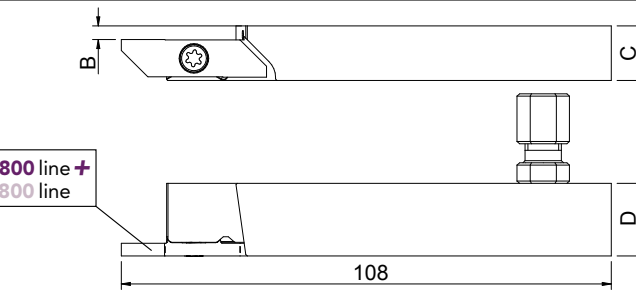
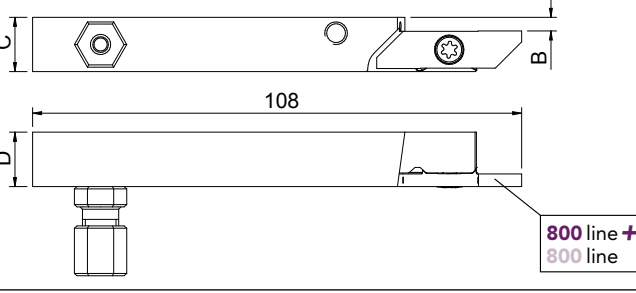
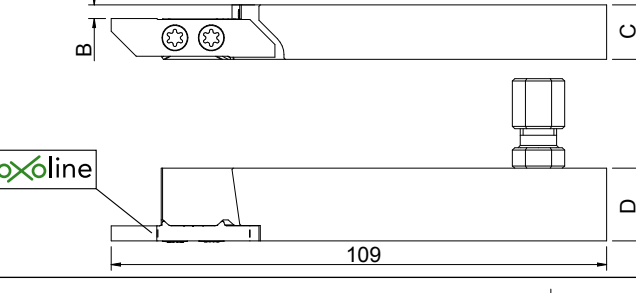
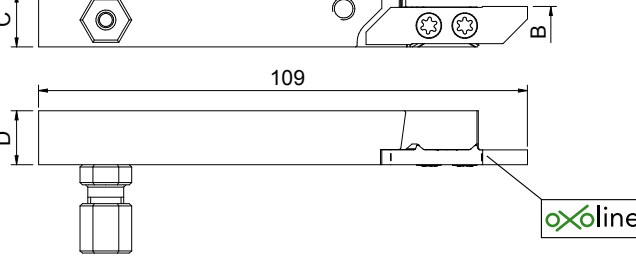
Tool holders with internal coolant Werkzeughalter mit Innenkühlung Porte-outils avec arrosage	CxD CxD CxD	B B B	Article nr. Artikel Nr. N° Article
 <p>ISO line VC...11...</p>	12x12 mm	4	SVCN 1212 H11 IK
	16x16 mm	4	SVCN 1616 H11 IK
 <p>800 line + 800 line</p>	12x15 mm	3	812R IK
	16x16 mm	3	816R IK
 <p>800 line + 800 line</p>	12x12 mm	3	812L IK
	16x16 mm	3	816L IK
 <p>oxoline</p>	12x15 mm	3	1012R IK
	16x16 mm	3	1016R IK
 <p>oxoline</p>	12x12 mm	3	1012L IK
	16x16 mm	3	1016L IK

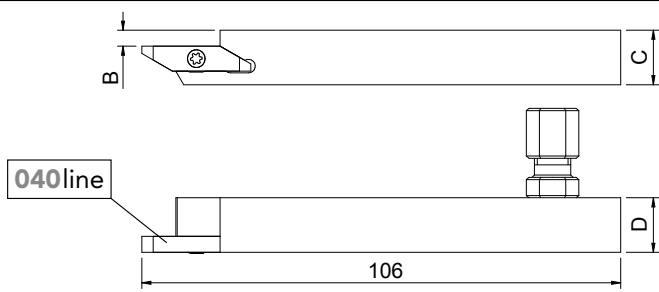
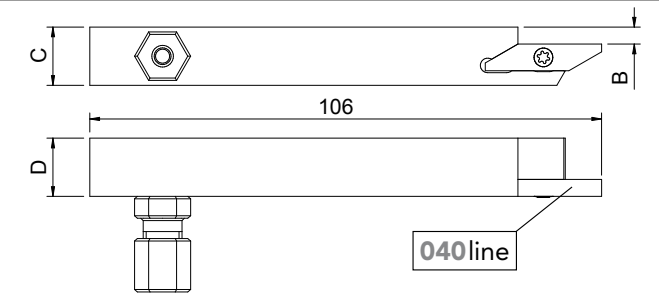
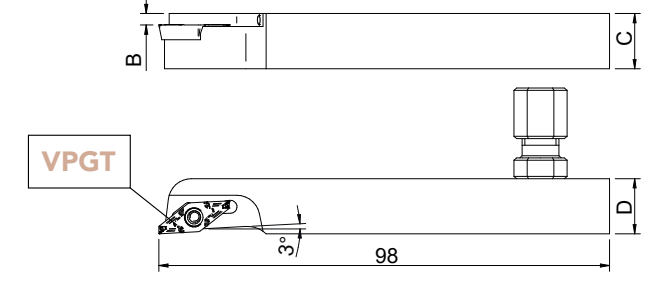
Tool holders with internal coolant Werkzeughalter mit Innenkühlung Porte-outils avec arrosage	CxD CxD CxD	B B B	Article nr. Artikel Nr. N° Article
 <p>040line</p>	10x12 mm	2,5	010R IK
	12x12 mm	3,5	012R IK
	16x16 mm	3,5	016R IK
	20x20 mm	3,5	020R IK
 <p>040line</p>	10x12 mm	2,5	010L IK
	12x12 mm	3,5	012L IK
	16x16 mm	3,5	016L IK
 <p>VPGT</p>	10x12 mm	2,5	SVJP R 1012 H10 IK
	12x12 mm	2,5	SVJP R 1212 H10 IK
	16x16 mm	2,5	SVJP R 1616 H10 IK



1 hydraulic fitting (M8x1, cone shape, output Ø 4 mm) is delivered with each tool holder.  
 1 hydraulischer Anschluss (M8x1, konisch, Ausgang Ø 4 mm) wird mit jedem Werkzeughalter geliefert.  
 1 raccord hydraulique (M8x1 conique, sortie Ø 4 mm) est livré avec chaque porte-outil.



To guarantee the smooth running of tool holders, the oil must be filtered in 60 µm.  
 Um einen reibungslosen Ablauf der Werkzeughalter zu gewährleisten, muss das Öl in 60 µm filtriert werden.  
 Afin de garantir le bon fonctionnement des porte-outils, l'huile doit être filtrée à 60 µm.

Replacement screw for tool holder... Ersatzschraube für Werkzeughalter... Vis de remplacement pour porte-outil...	Description Bezeichnung Description	Article nr. Artikel Nr. N° Article		
SDJCR 1012 H07 IK	M2,5 x 7,5	001-7		
SDJCR 1212 H07 IK				
SDJCR 1616 H07 IK				
SDJCR 1215 H11 IK	M3,5 x 7	100-2c		
SDJCR 1616 H11 IK	M3,5 x 9	100-2		
SDJCR 1212 H11 Y IK				
SDJCR 1616 H11 Y IK				
SVJCR 1015 H11 IK	M2,5 x 7,5	001-7		
SVJCR 1215 H11 IK				
SVJCR 1616 H11 IK				
SVJCR 1212 H11 Y IK				
SVJCR 1616 H11 Y IK				
SVVCN 1212 H11 IK				
SVVCN 1616 H11 IK				
SVJP R 1012 H10 IK				
SVJP R 1212 H10 IK				
SVJP R 1612 H10 IK				
812R IK			M4,5 x 10,5	100-4
816R IK				
812L IK				
816L IK				
1012R IK	M3,5 x 9	001-8		
1016R IK				
1012L IK				
1016L IK				

Replacement screw for tool holder... Ersatzschraube für Werkzeughalter... Vis de remplacement pour porte-outil...	Description Bezeichnung Description	Article nr. Artikel Nr. N° Article
010R IK	M2,5 x 7,5	001-2
012R IK		
016R IK		
020R IK		
010L IK		
012L IK		
016L IK		





Represented by    Vertreten durch    Représenté par

